

Department of Electrical & Electronics Engineering  
is organising  
National Level one week online FDP on

**RECENT DEVELOPMENTS IN GREEN TECHNOLOGIES**



## About the College

ATME College of Engineering (ATMECE), Mysuru, established in the year 2010 is approved by AICTE, New Delhi and affiliated to Visvesvaraya Technological University, Belagavi, Karnataka. ATMECE aims on providing the best of modern education with cutting edge technology to the students. ATMECE is rated GOLD by QS IGAUGE for its overall excellence and is an ISO 9001-2015 certified college and is awarded with "The Best Emerging Private Engineering college in Karnataka" and "Most promising upcoming private engineering college in Karnataka" were awarded for two consecutive years.

## About the Department

The Department of Electrical & Electronics Engineering was started in the year 2010 with an intake of 60 students. The department with its strong pool of faculty, well-equipped laboratories and latest software and hardware facilities emphasizes towards imparting quality education, hands-on expertise to students to shape their all-round personality.

The department offers Undergraduate program in Electrical & Electronics Engineering is accredited by NBA under MHRD for a period of three years. The department is also recognized as research Centre by Visvesvaraya Technological University (VTU).

## About the FDP

This FDP provides a unique platform for the faculties to get exposed to the Recent Development and Trends in the areas of Green Technologies. The faculty shall get an opportunity to interact with the experts to clearly understand the various concepts about the topics. The program intends to educate and upgrade the knowledge about the relevant topics in the fields related to Green Technologies.

## Course Duration

5 sessions in 5 days programme.

One session per day between

10:30 AM - 12:00 PM

## Program Objectives

- Updating the faculty about recent developments in green technologies.
- Motivating faculty to take up research work in this field.
- To share knowledge and experience on various aspects of green technologies.

## Program Outcomes

At the end of the program

- Faculties will get information about recent trends & development in the area of green technologies.
- Understand the impact of green technologies in societal and environmental contexts and its need for sustainable development.

## CHIEF PATRONS

**Sri. L. Arun Kumar**  
Chairman,  
ATMECE, Mysuru.

**Sri. Shivashankar M**  
Secretary,  
ATMECE, Mysuru.

**Sri. R. Veeresh**  
Treasurer,  
ATMECE, Mysuru.

## PATRON

**Dr. L. Basavaraj**  
Principal  
ATMECE, Mysuru.

## CONVENER

**Dr. Parthasarathy I**  
HOD, Dept. of EEE,  
ATMECE, Mysuru

## FACULTY CO-ORDINATORS

**Mr. Raghavendra L**  
Associate Professor  
Dept. of EEE, ATMECE

**Dr. Sathish K R**  
Assistant Professor  
Dept. of EEE, ATMECE

## FURTHER DETAILS CONTACT

**Dr. Sathish K R**  
Assistant Professor  
Dept. of EEE, ATMECE  
Contact No: 9611982696

## REGISTRATION LINK:

Only online registration of participants to be done through

<https://forms.gle/6bdXQ6SükTcHECD9>

No registration fee will be charged from the participants.

## Target Audience:

Faculty Members and Research Scholars from the Engineering Colleges recognized by AICTE / UGC.

E-Certificate will be issued to the participants who attend the program.

## Important Dates

Last date of online registration: 21st Sep 2021

Intimation of participants: 22nd Sep 2021

Event dates: 24th to 29th Sep 2021

## Department of Electrical and Electronics Engineering

### “Report on One Week National Level Online Faculty Development Programme on Recent Developments in Green Technologies”

**Organizing Department: Department of Electrical & Electronics Engineering**

**Program Convener: Dr.Parthasarathy L, HoD, Department of EEE**

**Event Coordinators: Mr. Raghavendra L, Dr. Sathish K R**

The Department of Electrical & Electronics Engineering had conducted a One Week National Level Online Faculty Development Programme on “**Recent Developments in Green Technologies**” from 24<sup>th</sup> September to 29<sup>th</sup> September, 2021 through virtual platform

Ms.Swapna H, Assistant Professor, Welcomed the dignitaries and participants.

Dr. L Basavaraj, Principal, ATME College of Engineering, Mysuru addressed the participants on the importance of Green technology and sustainable development, the role of engineers in the society. He urged the participants to gain insights and work towards progressive technologies for the benefit of the society.

Dr. Parthasarathy L, HoD, Department of Electrical & Electronics Engineering, ATMECE,Mysuru, Dr.Vijay Babu Koreboina, Assistant Professor, Department of Mechatronics Engineering, Manipal Institute of Technology, Manipal, Dr.Sanjeev Nayak,Assistant Professor, Dept of Electrical and Electronics Engineering, P D A College of Engineering, Kalaburagi Dr.Suresh Jangamashetti, Professor,Department of E&EE, Basaveshwar Engineering College, Bagalkot, Dr Dastagiri Reddy, Assistant Professor, Department of Electrical and Electronics Engineering, National Institute of Technology Karnataka, Surathkal were the resource persons.

In the weeklong event, Resource Persons delivered session on green technology that included Battery technology, Electric Vehicles, Power source for EVs, Solar PV and Wind Energy for low power application, Smart integration of renewable energy to AC grid. The forum was kept open for discussion after each session. More than 100 participants from PAN India Participated in the event.

Green technology helps reduce a business' carbon footprint, reduces waste, conserves water and consumes reduced energy as compared to traditional technologies. The green energy sector is responsible for a host of job opportunities on the market today. The trending R& D on Green technologies, The role of electric vehicles in 21<sup>st</sup> century and its relevance to India was addressed during the event. The event was a stepping stone for exchange of valuable information on concurrent technology

## Department of Electrical and Electronics Engineering

Mr. Raghavendra L, Associate Professor and Dr. Sathish K R, Assistant professor were the event coordinators.

In the valedictory session on the final day, Mr. Shreeshayana R, Assistant Professor, rendered vote of thanks. Certificates were distributed to all participants post feedback.

### Inauguration:

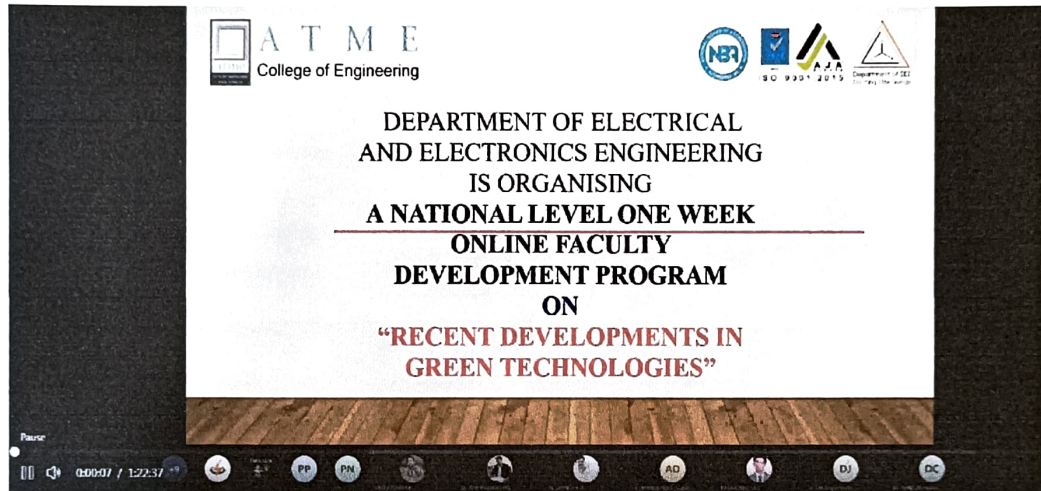

### During the Session:

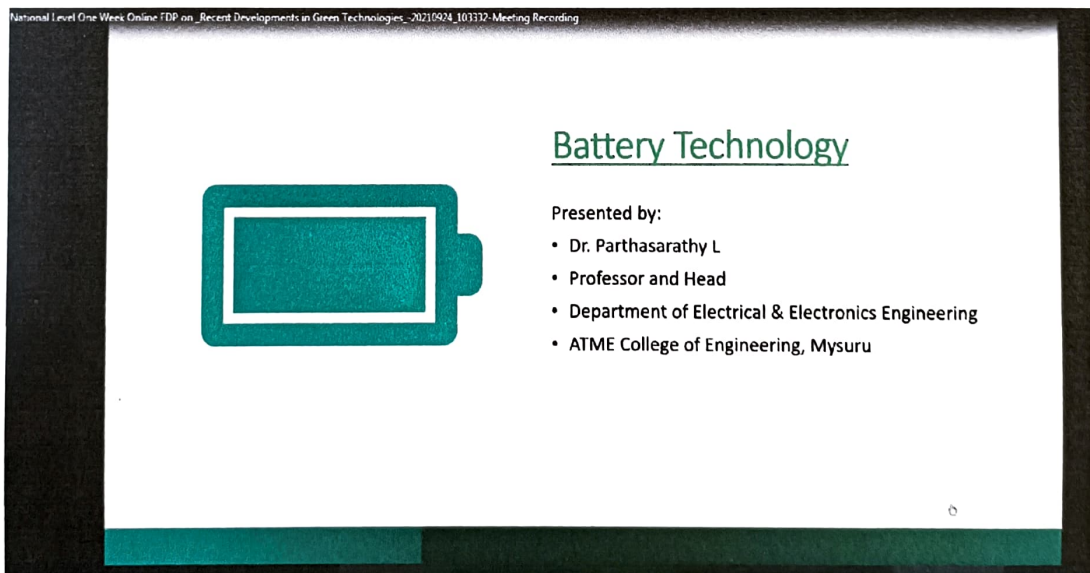

The screenshot shows a presentation slide titled "Battery Technology". On the left, there is a green battery icon. On the right, the text reads: "Presented by: Dr. Parthasarathy L, Professor and Head, Department of Electrical & Electronics Engineering, ATME College of Engineering, Mysuru". The slide is part of a meeting recording titled "National Level One Week Online FDP on Recent Developments in Green Technologies -2021/09/24\_10:33:32-Meeting Recording".

  
Dr. PARTHASARATHY L.  
Professor and HOD  
Dept. of Electrical & Electronics Engineering  
ATME College of Engineering, Mysuru

## Department of Electrical and Electronics Engineering



ATME  
College of Engineering



### Contents

- Why Batteries?
- Classification
- Cell/Battery
- Focusing in on the EV Battery
- Battery Metrics
- Performance indices and Characteristics
- Production of EV Batteries
- Battery comparison
- Energy storage technologies
- Saving in carbon footprint
- Re Use of EVB
- Second life of EVB
- Recycling
- Scope to research
- References



Dr Parthasarathy L, Department of EEE, ATMECE, Mysuru



ATME  
College of Engineering

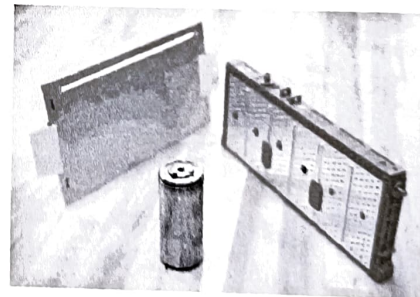
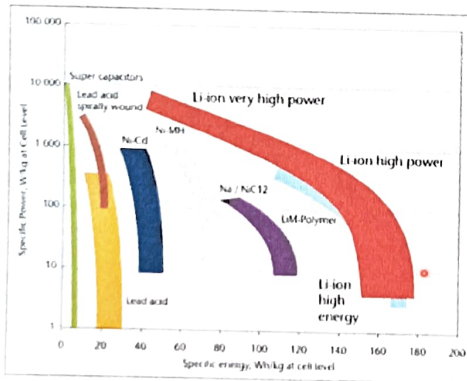

24-09-2021

Dr Parthasarathy L, Department of EEE, ATMECE, Mysuru

41



*Dr. Parthasarathy L.*  
Professor and HOD  
Dept. of Electrical & Electronics Engineering  
ATME College of Engineering, Mysuru

## Department of Electrical and Electronics Engineering



**A T M E**  
College of Engineering



Design a Battery Bank for:

- System load of 6000Wh
- Autonomy of 3 days
- DoD is 40%
- Battery bank ambient temp is 60 degF
- 48V system voltage

Calculations:

Step1: 6000Wh per day

Step2: Autonomy therefore  $3 \times 6000\text{Wh} = 18000\text{Wh}$

Step3: For 40% DoD =  $18000 / 0.4 = 45000\text{Wh}$

Step4: Temp effect =  $45000 \times 1.11 = 49950\text{Wh}$

Step5: Dividing step4 by system voltage:  
 $49950 / 48 = 1040\text{Ah}$ .

14-09-2021

Dr Parthasarathy L, Department of EEE, ATMECE, Mysuru

61

SR

VU

AB

SB

S

AD

TK

VMOD KEMAR P

Dr. SATHISH K R

RAJASHEKAR L

PARTHASARATHY L

## EV's : A Top-up for Green Energy

By  
Dr. SANJEEV KUMAR R A  
Asst. Prof., PDA college of engineering, Kalaburagi  
Email: [sanju.san999@gmail.com](mailto:sanju.san999@gmail.com)  
9739459297

Feedback is useful to improve your screen. [Stop sharing](#) [Help](#)

SM

PP

PN

RK

DL

DC

D



Dr. PARTHASARATHY L.  
Professor and HOD  
Dept. of Electrical & Electronics Engineering  
ATME College of Engineering, Mysuru

## Department of Electrical and Electronics Engineering

*National Level One Week Online FDP on*  
**Recent Developments in Green Technologies**  
24-29 Sep 2021 *Organizers: EEED ATMECE Mysuru*

*Part-A Webinar on*  
**Carbon Footprint for Academic Campuses**

*Dr. Suresh. H. Jangamshetti*

Senior Member IEEE & Fulbright Alumni

**Professor and HoD EEE**

**Basaveshwar Engineering College (Autonomous)  
Bagalkot-587103, Karnataka State, INDIA**

**25.09.2021 10:30 – 12:00 Hrs**



### India New EV Program

- Govt. focus on **electrification of transportation**
- Early EV **penetration in public transport**  
E-rickshaw, E-auto, Taxis, Buses
- Strategy – **Aggregation of demand** (by EESL)
- EESL tender for **10,000 EV sedan cars** and **2000 Bharat EV Chargers**
- DHI EoI for **STUs** for electric bus operation and public charging stations
- Standardisation of **tender specifications** for electric buses by DHI
- **Model Concession Agreement** for Opex model by Niti Aayog for electric bus fleet operation



**Dr. PARTHASARATHY L.**  
Professor and HoD  
Dept. of Electrical & Electronics Engineering  
ATME College of Engineering, Mysuru

**Department of Electrical and Electronics Engineering**

**Managed Charging by Utility**

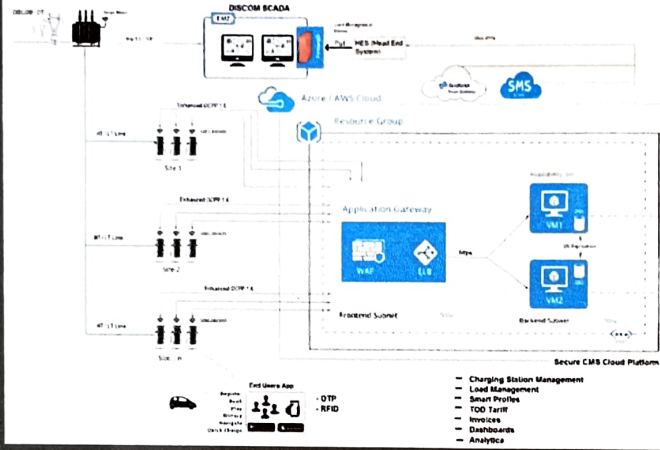

**Electric Vehicle Charging Technologies**

Charging level	Voltage	Charging mode	Typical power	Location
Level 1	120 V AC	-	1.2-1.8 kW AC	Primarily residential in North America
Level 2	200-240 V AC	Mode 1	3.6-11 kW AC	Wall socket in Europe; Primarily for 2 & 3 Wheelers
		Mode 2	3.6-22 kW AC	Home and workplace with cable or basic station
		Mode 3	3.6-22 kW AC	Home, workplace and public with hardwired station
Fast Charging	400-1000 V DC	Mode 4	50 kW or more	Public, frequently intercity

**Dr. PARTHASARATHY L.**  
Professor and HOD  
Dept. of Electrical & Electronics Engineering  
ATME College of Engineering, Mysuru

## Department of Electrical and Electronics Engineering



Renewable Energy Park - funded by MNRE-KREDL and BVVS (2007)



### • Understanding Carbon Footprint

**Carbon footprint** relates to the amount of greenhouse gases (GHGs) produced in our day to day lives through burning of fossil fuels for electricity, heating and transportation, etc. It is a measurement of all GHGs individually produced and their units of tones (or kilogram) of CO<sub>2</sub> equivalent.



28-09-2021



Dr. PARTHASARATHY L.  
Professor and HOD  
Dept. of Electrical & Electronics Engineering  
ATME College of Engineering, Mysuru



**Department of Electrical and Electronics Engineering**

**SMART INTEGRATION OF RENEWABLE ENERGY SOURCES TO AC GRID**

By  
**Dr. B. Dastagiri Reddy**



Acknowledgements: Dr. Priyesh Chuhan, Dr. S. K. Panda, Mr. S. Bandari, EMDL, NUS Singapore,



**NATIONAL RESEARCH FOUNDATION**  
PRIME MINISTER'S OFFICE  
SINGAPORE

7/2/2021



**BES + UTILITY GRID**

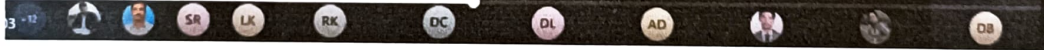
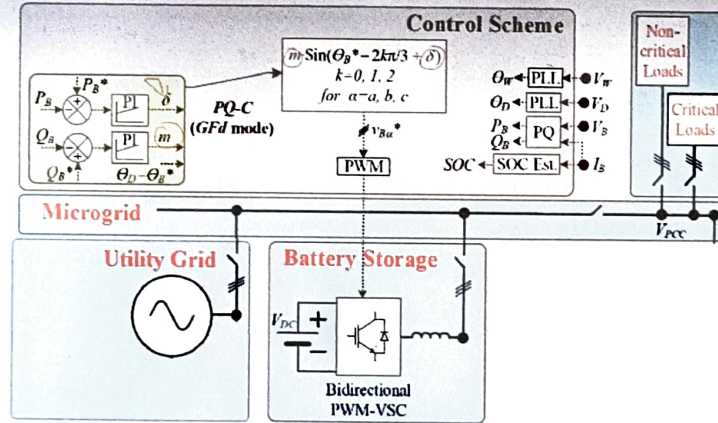

Dr. PARTHASARATHY L.  
Professor and HOD  
Dept. of Electrical & Electronics Engineering  
A T M E College of Engineering, Mysuru



## Department of Electrical and Electronics Engineering

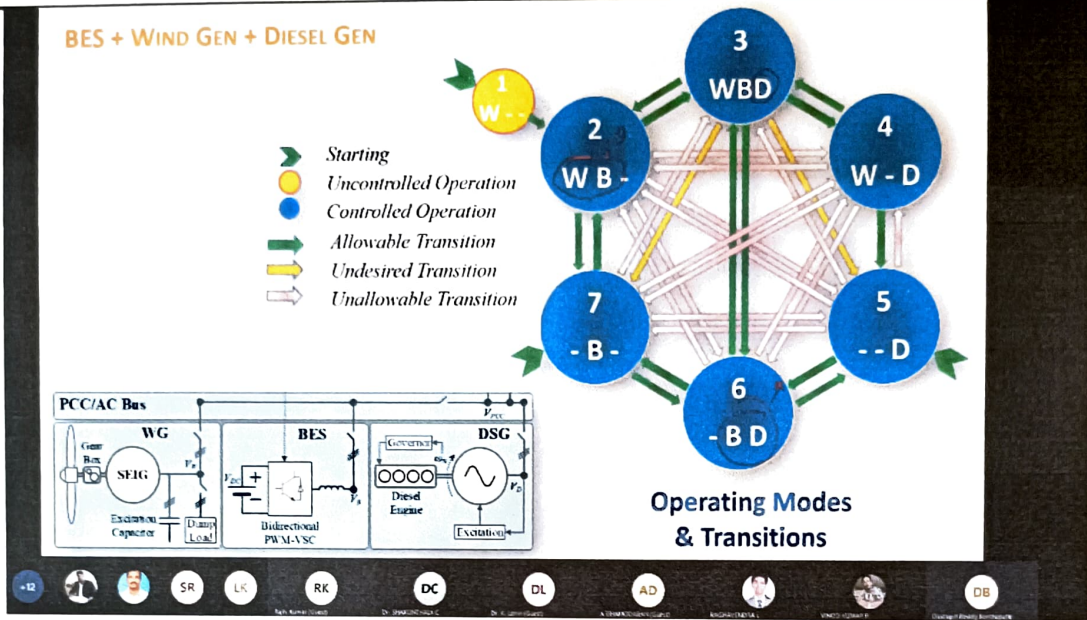

Dr. PARTHASARATHY L.  
 Professor and HOD  
 Dept. of Electrical & Electronics Engineering  
 A.T.M.E. College of Engineering, Mysuru



## Department of Computer Science & Engineering

---

### Faculty Development Program on “Networking”

**Organizing Department Name:** Department of Computer Science & Engineering.

**Event type:** Inter College.

**Mode :** Online

**Title of the event:** “Network-king”

**Date:** 05/04/2021 and 09/04/2021

**Venue:** Department of Computer Science & Engineering, ATMECE.

**Resource person/Guest: Name:** Mr Anil Kumar and Mr Kiran B,

**Designation:** Assistant Professor

**Event Description:** Conducting five days of FDP on “Network-king” in CS Dept. This FDP is targeted to faculties of various diploma colleges.

**Objective:** This course is designed to impart knowledge about detailed knowledge of Computer Networks, various protocols used in Communication, Managing and configuring Cisco Switches and Routers and various WAN technologies.

The Department of Computer Sciences Engineering had signed MoU with CISCO Systems, Bangalore on 21-01-2018. The CISCO center of excellence on Advanced Networking available in the department provides world class networking infrastructure. The faculty members have been constantly trained by CISCO Networking Academy, to offer the latest industry relevant networking curriculum. The Department is offering the certification course CCNA (Cisco Certified Network Associate) to the students since

## Department of Computer Science & Engineering

The course provides experience to the faculties on networking concepts for 5days. Faculty in charge are Anil Kumar B H, Kiran Kumar B.

Day 1: Introduction to network and Packet tracer.

Day2: Classes of IP address.

Day3: Configuration of router and switch.

Day 4: Subnetting

Day 5 : Configuration of TFTP server

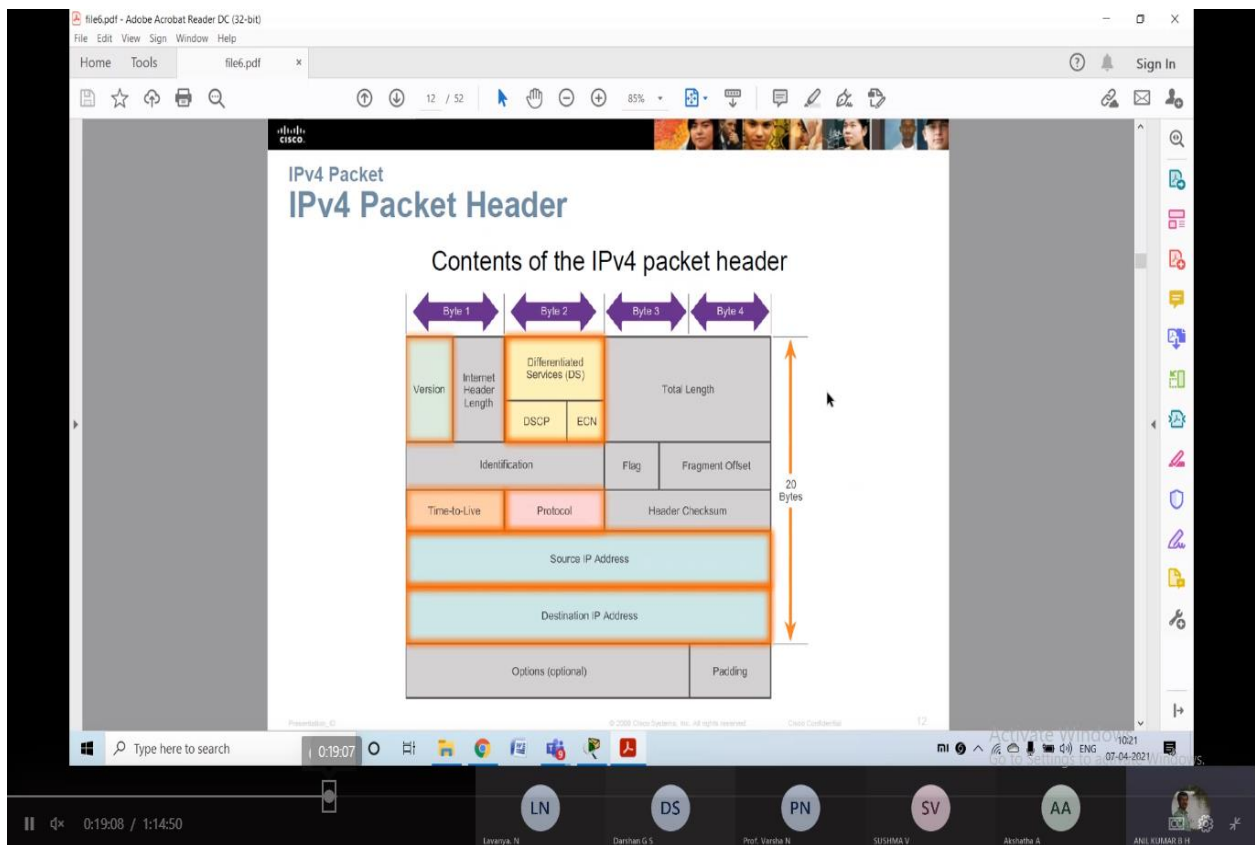

The screenshot shows a presentation slide titled "IPv4 Packet Header" with the subtitle "Contents of the IPv4 packet header". The slide displays a diagram of the IPv4 header structure, which is 20 bytes long. The header is divided into four bytes:

- Byte 1: Version (4 bits) and Internet Header Length (4 bits)
- Byte 2: Differentiated Services (DS) (6 bits) and DSCP (6 bits)
- Byte 3: ECN (2 bits) and Total Length (16 bits)
- Byte 4: Total Length (16 bits)

The diagram also shows the following fields:

- Identification (16 bits)
- Flag (3 bits) and Fragment Offset (13 bits)
- Time-to-Live (8 bits) and Protocol (8 bits)
- Header Checksum (16 bits)
- Source IP Address (32 bits)
- Destination IP Address (32 bits)
- Options (optional) and Padding

The slide is displayed in a window titled "file6.pdf - Adobe Acrobat Reader DC (32-bit)". The window shows the standard Adobe Acrobat Reader interface with a menu bar (File, Edit, View, Sign, Window, Help), a toolbar, and a sidebar. The presentation is being viewed in a full-screen mode. The Windows taskbar is visible at the bottom, showing the search bar, task view, and various application icons. The system tray shows the date and time as 10:21 on 07-04-2021. The presentation controls at the bottom of the window show a play button, a progress bar at 0:19:08 / 1:14:50, and several circular buttons labeled LN, DS, PN, SV, and AA.

**Outcome:** After completion of the course the faculties will be able to manage network for an Organization.



## Department of Computer Science & Engineering

**A T M E**  
College of Engineering  
Department of Computer Science and Engineering

**Resource Persons**  
**Anilkumar BH & Kiran B**  
Certified CCNA Trainer  
CISCO Center of Excellence, ATMECE.  
Mob : 9916732611 / 8095620284

---

**Event Type:**  
Inter College  
**Title of the Event:**  
FDP on "CCNA-Module I"  
**Mode of Conduction:**  
Online / Offline - MS Teams  
(Based on Faculty Request)  
**Timings:**  
10:00 AM to 1:00 PM or 30 Hours

**Event Description**  
Conducting five days FDP on "CCNA-Module I" in CS Dept. This FDP is targeted to faculties of Diploma colleges and in-house faculty members.

**Course Content**  
This module introduces the architecture, structure, functions, components, and models of the Internet and computer networks. The principles of IP addressing and fundamentals of Ethernet concepts, media, and operations are introduced to provide a foundation for the curriculum. By the end of the course, you will be able to build simple LANs, perform basic configurations for routers and switches, and implement IP addressing schemes.

**Registration Link:**  
[https://docs.google.com/forms/d/1XTYlIteDu9kr\\_58WTFEDe5MUWhdN4Pr3E\\_6IhdOKWvg/edit?usp=sharing](https://docs.google.com/forms/d/1XTYlIteDu9kr_58WTFEDe5MUWhdN4Pr3E_6IhdOKWvg/edit?usp=sharing)

Certificate has been issued for the participants.

**A T M E**  
College of Engineering  
ATME College of Engineering  
13th Kilometre, Mysore - Kanakapura - Bangalore Road. Mysore - 570 028  
Department of Computer Science and Engineering

### Certificate

Certificate ID: KFSEAE-CE000015

This is to certify that Akshatha A of ATMECE, Mysuru successfully completed Faculty Development Programme on **"Network-king"**, with **CCNA Module I** from 05<sup>th</sup> to 9<sup>th</sup> April 2021 organized by Department of Computer Science and Engineering, ATMECE, Mysuru.

\_\_\_\_\_  
Anilkumar B H  
Asst. Prof.  
Coordinator

\_\_\_\_\_  
Dr. Puttegowda D  
Prof & HoD  
Dept. of CSE

\_\_\_\_\_  
Dr L Basavaraj  
Principal  
ATMECE

Certificate Sample

Coordinator

HOD



## **Report**

### **Webinar on “A Process approach to Writing Research Articles-for Beginners”**

The Research, Publication & Co-Curricular Activities Committee, ATMECE is organizing a webinar on “A Process approach to Writing Research Articles-for Beginners” On 26<sup>th</sup> August 2021 for research scholars and faculties of ATMECE. The webinar was conducted in MS Teams platform and a total of 44 participants from ATMECE had participated. The webinar was scheduled at 3 PM with formal introduction about the webinar followed by brief introduction of resource person.

Dr. Mahesh Lohith K S, Associate Professor and Head, Department of Physics was kind enough to accept our invitation as resource person to educate the research scholars and faculty members of various educational streams about the importance research article in research and innovation.

Dr. Bhagyashree S R, Dean-Research and professor, ATMECE, is the convenor of the program.

Dr. Md Nadeem M, Assistant. professor, Dept of ME & Dr. Sathish K R, Assistant. professor, Dept of EEE hosted the webinar.

Dr. Mahesh Lohith K S discussed about the importance of writing Research Articles & Thesis.

Dr. Mahesh Lohith K S emphasized the importance on research topic and title, Feasibility Study Process Setup and Execution.

At the end Mr. Anilkumar C J Associate Professor, Department of CSE concluded the webinar by giving vote of thanks to Dr. Mahesh Lohith K S, Management of ATMECE, Dean, HODs and all the participants. Feedback form was floated to all the participants through participant's respective email IDs for effective management and documentation.



Affiliated to VTU, Belagavi; Approved by AICTE, New Delhi and Recognised by Government of Karnataka  
Programs accredited by NBA, New Delhi - CV, EC, EE & ME (Validity: 2019-20 to 2021-22)

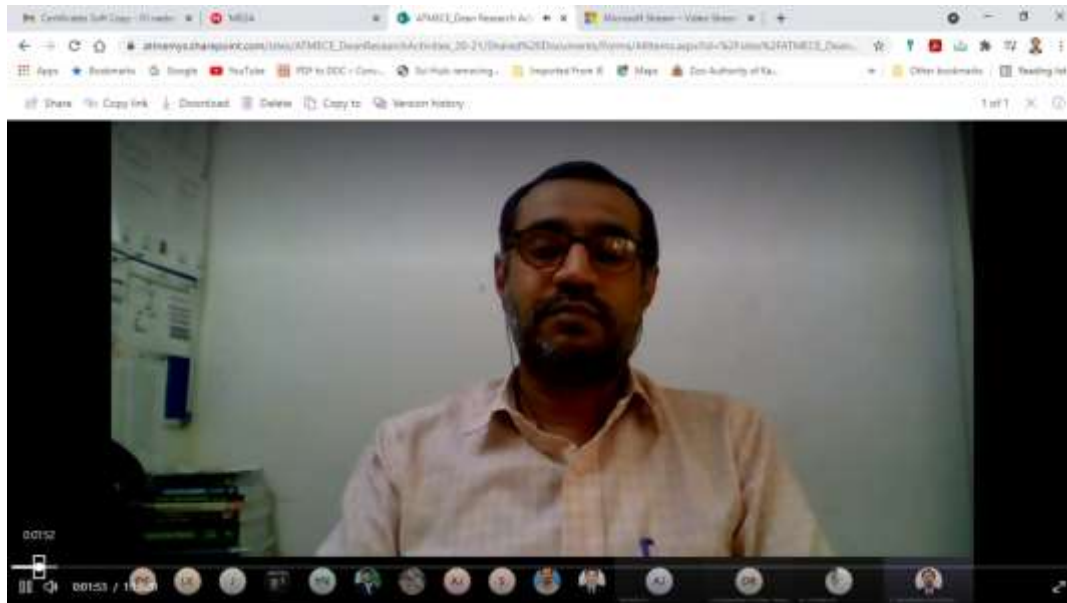

Pic : Resource Person Mahesh Lothith K S addressing Session

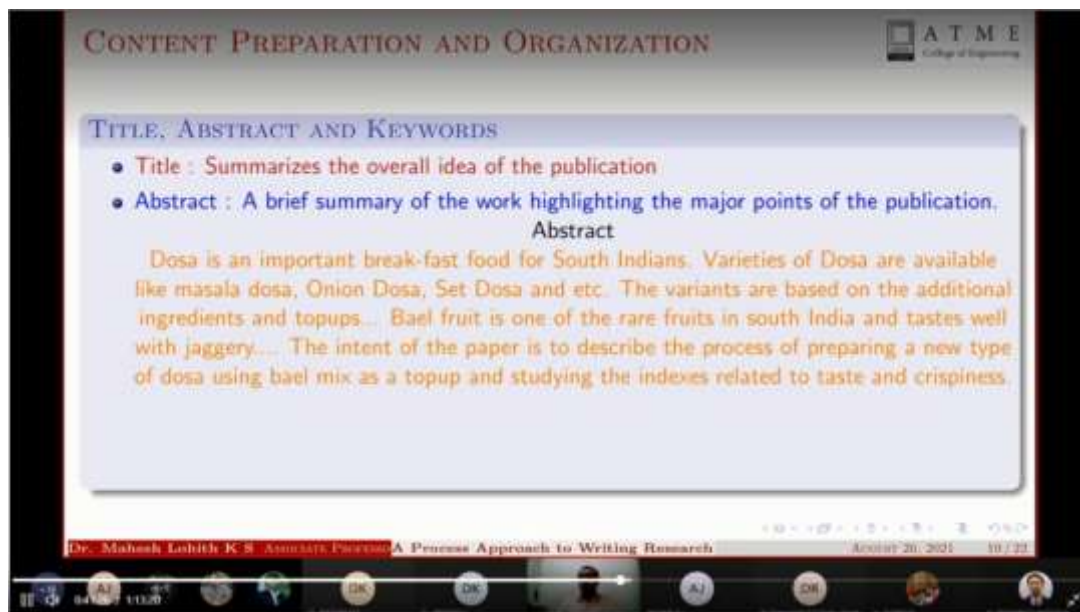

**Organizing Coordinators**

Dr. Sathish K R

Dr. Md Nadeem M

for ATME College of Engineering

Dean Research



# A T M E

College of Engineering



# NBA

ACCREDITED

Affiliated to VTU, Belagavi; Approved by AICTE, New Delhi and Recognised by Government of Karnataka  
Programs accredited by NBA, New Delhi - CV, EC, EE & ME (Validity: 2019-20 to 2021-22)

Report  
on  
3-Day National Level Faculty Development Program  
“Importance of NAAC Accreditation in Higher  
Education Institutions”

Organized by  
ATME College of Engineering  
(09-11-2020 to 11-11-2020)

A Three-day national level faculty development programme on “Importance of NAAC accreditation in higher education institutions” was conducted from 9th to 11th November 2020 under the decennial celebration banner of ATME college of engineering. About 125 participants were registered among which 20 external participants from various engineering colleges across the nation.

The main motto of the faculty development program is to focusses on awareness of NAAC accreditation process along with seven associated criteria’s and its documentation and to provide the knowledge on formulating the self-study report for higher education affiliated institutions.

Eminent personalities like Dr.Vivek Kapur, Dr.Mangala Keshava and D. Nagesh Prabhu were the external speakers to the faculty development program along with 3 internal speakers namely Dr Govinde Gowda M S, Dr Mahesh P K and Dr. Yathisha L.

The online faculty development program was coordinated by Dr. Yathisha L, Girish M, Sneha N P and Kiran B, Assistant Professors, ATME College of Engineering. **The entire program was live streamed in YouTube.**

The faculty development programme was inaugurated by our beloved principal Dr. L. basavaraj through his presidential speech.

ATME COLLEGE OF ENGINEERING

13th Kilometer, Mysore-Kanakapura-Bangalore Road, Mysore - 570 028 P: 0821-2593335 F: 0821-2593328

Email : info@atme.in Web : www.atme.in



**Day 1:**



**Dr. Vivek Kapur,**

**Director,**

**G H Raison Institute of Engineering and Technology, Nagpur**

He started the first session of the FDP with how the vision, mission program educational objectives should be defined at the institute level. How these influence the reputation of the institution in the society and through his expertise he completely explains about CO, PO and PSO attainment processes that need to take place at the institute level with his very own examples. Speech includes the complete content which will be shown in the criteria 1 and criteria 2 in the accreditation process. Following figures show the sample pictures of the session during his content delivery.

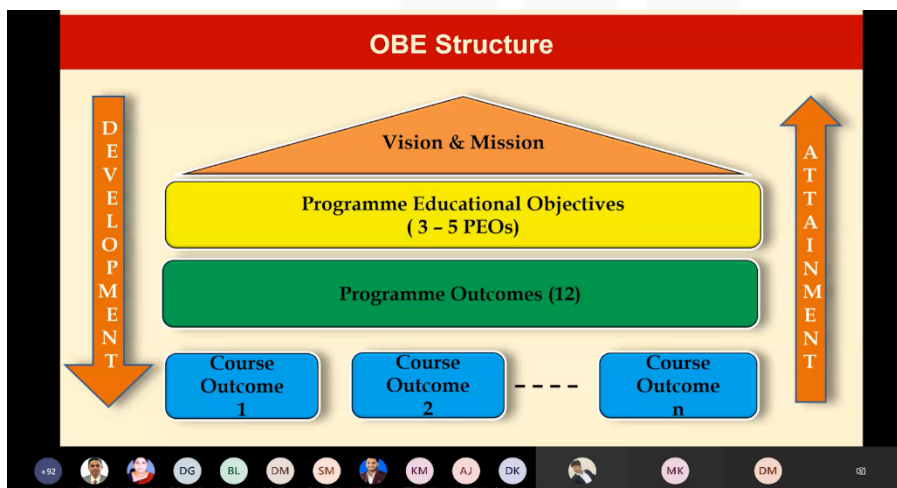



**Dr. Yathisha L.**  
**Associate Professor,**  
**Dept. of ECE**  
**ATME College of Engineering**

He started the second session of day 1 with a weightage of marks to each and every subcriteria of criteria 1 and 2 in NAAC along with the complete information on the documentation to be shown in front of the peer review committee when they visit the campus. Also he explained how the teaching learning and evaluation play a vital role in the accreditation process.

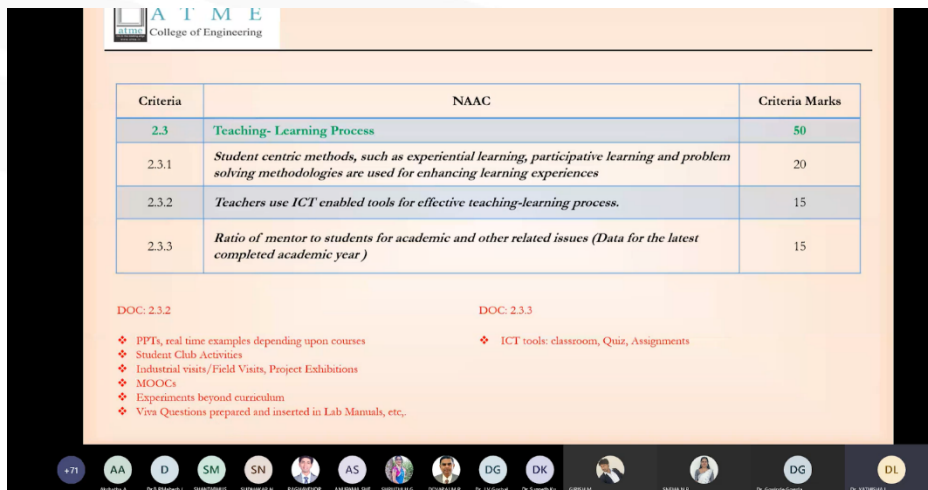

Criteria	NAAC	Criteria Marks
2.3	<b>Teaching- Learning Process</b>	50
2.3.1	<i>Student centric methods, such as experiential learning, participative learning and problem solving methodologies are used for enhancing learning experiences</i>	20
2.3.2	<i>Teachers use ICT enabled tools for effective teaching-learning process.</i>	15
2.3.3	<i>Ratio of mentor to students for academic and other related issues (Data for the latest completed academic year )</i>	15

DOC: 2.3.2

- ❖ PPTs, real time examples depending upon courses
- ❖ Student Club Activities
- ❖ Industrial visits/Field Visits, Project Exhibitions
- ❖ MOOCs
- ❖ Experiments beyond curriculum
- ❖ Viva Questions prepared and inserted in Lab Manuals, etc.

DOC: 2.3.3

- ❖ ICT tools: classroom, Quiz, Assignments

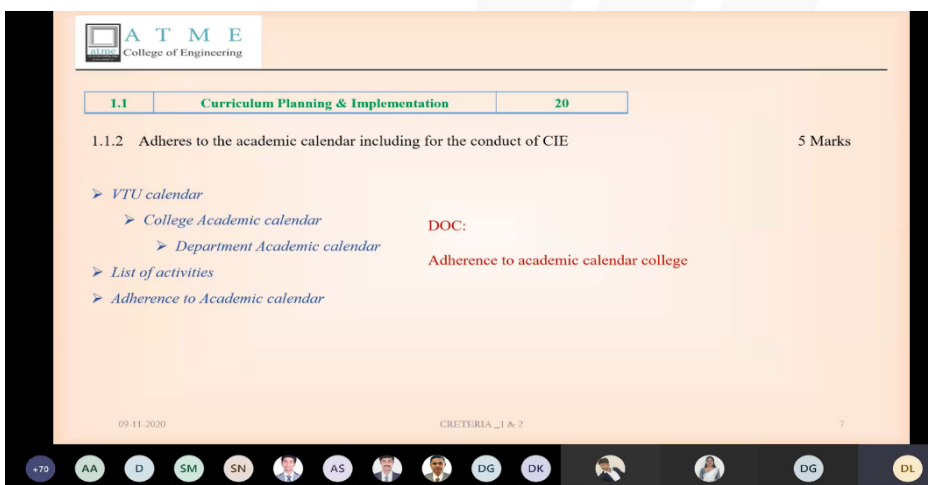

Criteria	NAAC	Criteria Marks
1.1	<b>Curriculum Planning &amp; Implementation</b>	20
1.1.2	<i>Adheres to the academic calendar including for the conduct of CIE</i>	5 Marks

DOC:

- Adherence to academic calendar college

09-11-2020

CRITERIA\_1 & 2

## Day 2:



**Dr. Mangala Keshava IQAC Director,  
BMS College of Engineering  
Bangalore.**

She started the first session of Day 2 with an explanation of the accreditation framework of NAAC based on five core values. Briefed about the role of IQAC, IQAC core committee members, responsibilities of IQAC, major IQAC activities to be carried out. Outlined the data requirement for self-study report. Described about Criteria 3 Research, innovations and extensions.

Sample pictures of the session is as follows:

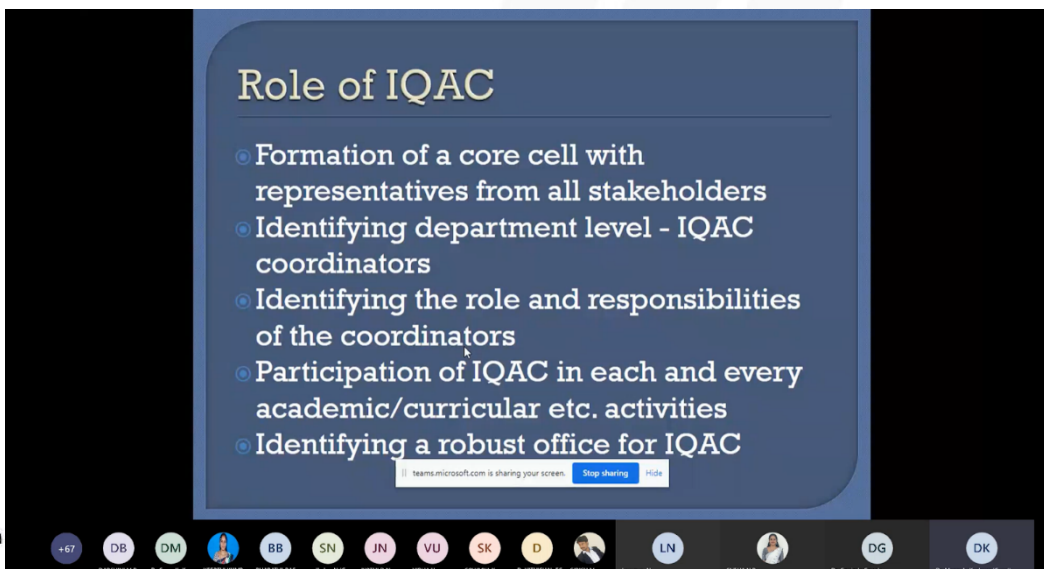



# A T M E

## College of Engineering



# NBA ACCREDITED

Affiliated to VTU, Belagavi; Approved by AICTE, New Delhi and Recognised by Government of Karnataka  
Programs accredited by NBA, New Delhi - CV, EC, EE & ME (Validity: 2019-20 to 2021-22)



**Dr. Mahesh P K**  
**Professor & Head,**  
**Dept. of ECE, IQAC Coordinator,**  
**ATME College of Engineering, Mysuru**

He started the second session of Day 2 by explaining NAAC guidelines for Criteria 4- Infrastructure and learning resources. Discussed about the physical infrastructure for teaching and learning process, support facility, adequate facilities for cultural sports, Learning management system, e-resource subscription, expenditure for infrastructure augmentation, library expenditure and integrated library management systems. Also explained about the role of website in accreditation.

4.1.1. QIM The adequacy of infrastructure and physical facilities for teaching-learning (5M)

Answer: (500 words)

Overall general description with 500 words comprising:

- ⑩ Claim infrastructure as per the regulations (University/ AICTE)
- ⑩ Mention Quantitative information Such as Numbers and Ratios.
- ⑩ Show as per the Standards (ISO, etc.)
- ⑩ Academic support systems.
- ⑩ Policy of optimal use and procedures for its development/maintenance
- ⑩ Unique Infrastructure for some special program (if any)
- ⑩ ICT infrastructure.
- Anything Other (Recreation, Canteen, medical center, restrooms etc)

ATME College of Engineering

**ATME COLLEGE OF ENGINEERING**

13th Kilometer, Mysore-Kanakapura-Bangalore Road, Mysore - 570 028 P: 0821-2593335 F: 0821-2593328

Email : info@atme.in Web : www.atme.in

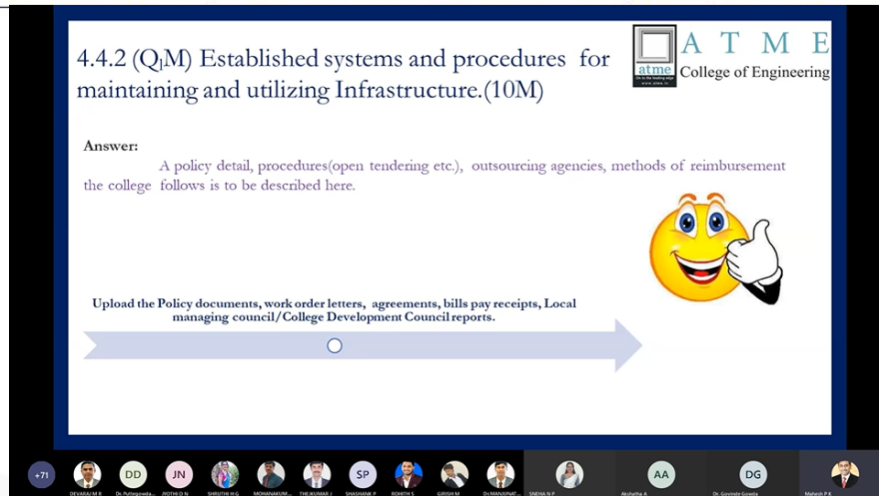

### Day 3:



**Dr. Nagesh Prabhu**

**Professor & Head, EEE Department, NMAM Institute of Technology Mangalore**

He started the first session of day 3 by discussing the revised assessment and accreditation framework, Quality indicator framework. Key indicators, qualitative and quantitative metrics were explained in detail. Discussed about NAAC Criteria 5: Student support and progression, student participation and activities, alumni engagement. Outlined about Criteria 6-Governance leadership and management- institutional vision and leadership. Also explained about the NAAC SSR preparation for Criteria 5 and 6.

Affiliated to VTU, Belagavi; Approved by AICTE, New Delhi and Recognised by Government of Karnataka  
Programs accredited by NBA, New Delhi - CV, EC, EE & ME (Validity: 2019-20 to 2021-22)

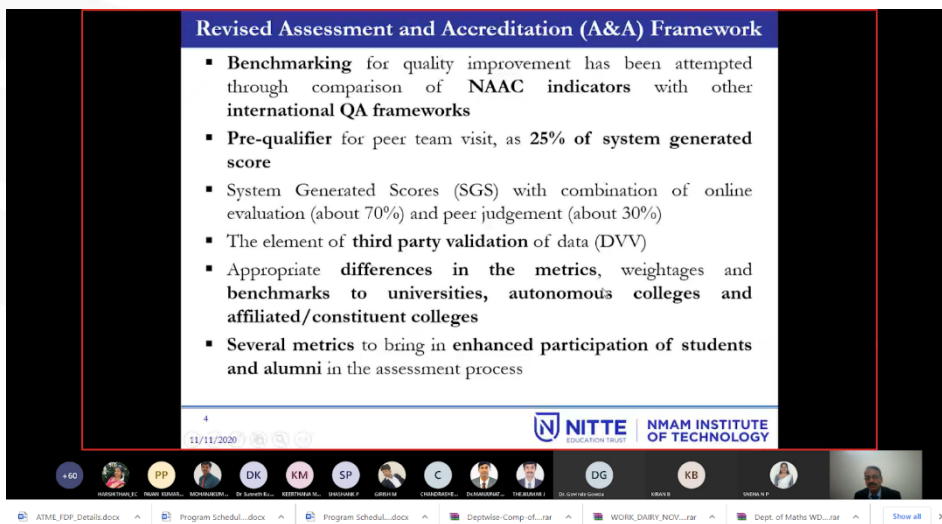

**Dr. Govinde Gowda M S**  
**Dean-Academics,**  
**ATME College of Engineering, Mysuru**

He started the last session of the FDP with Criteria 7 which includes the institute values and social responsibilities possessed by the institution.

He deliberated with several examples where the ATME has deployed the mechanisms for supporting gender equality, green campus environment, and support for energy conservation. Discussed about the institute having disabled friendly, barrier free environment. Outlined the best practices followed in the institute i, student response system and 360 faculty appraisal.

Affiliated to VTU, Belagavi; Approved by AICTE, New Delhi and Recognised by Government of Karnataka  
Programs accredited by NBA, New Delhi - CV, EC, EE & ME (Validity: 2019-20 to 2021-22)

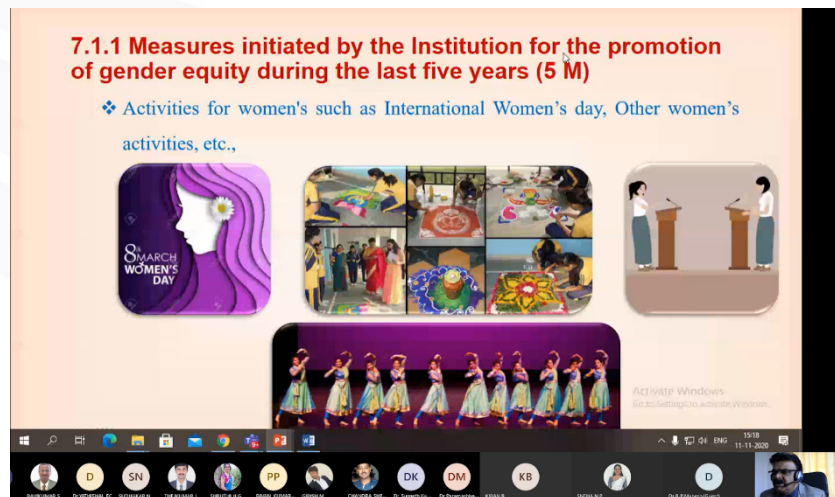

As a part of the program **Pre-assessment test** was conducted on to the participants to assess the awareness about the NAAC accreditation process and its terminologies prior to the starting of the FDP.

Followed by the **Post-assessment test** was conducted on 11/11/2020 after the conclusion of the program to evaluate how effectively the contents reached the participants.

Feedback about program by the participants on various factors as follows:

**Question: Topic of the FDP was relevant and interesting**



Affiliated to VTU, Belagavi; Approved by AICTE, New Delhi and Recognised by Government of Karnataka  
Programs accredited by NBA, New Delhi - CV, EC, EE & ME (Validity: 2019-20 to 2021-22)

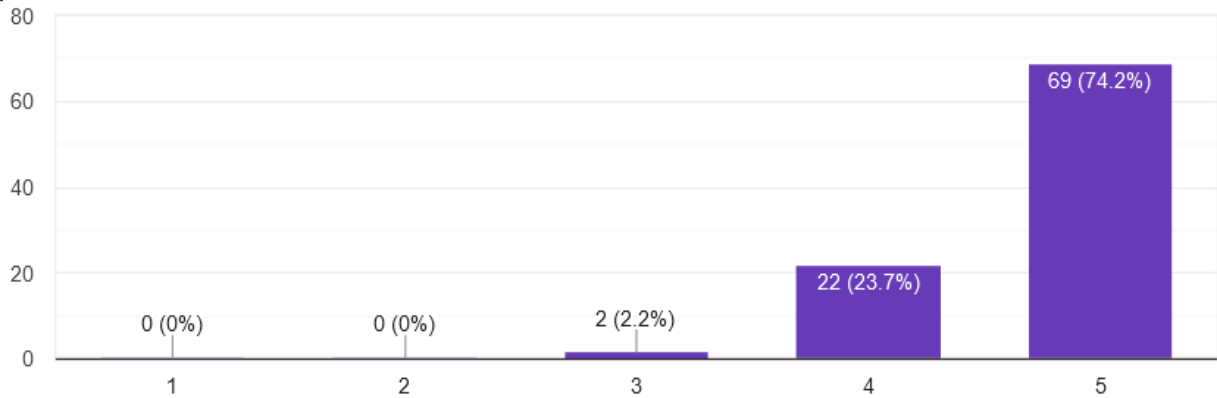

Question: The Speaker provided adequate information and helped the participants to understand about the topic delivered

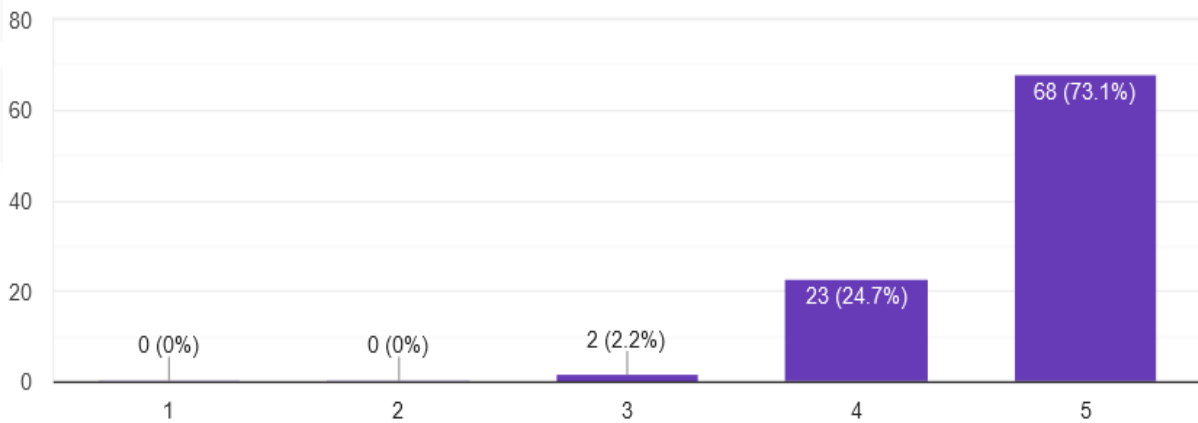

Question: The Content of the FDP met the expectations of the participants





# A T M E

## College of Engineering



# NBA ACCREDITED

Affiliated to VTU, Belagavi; Approved by AICTE, New Delhi and Recognised by Government of Karnataka  
**Programs accredited by NBA, New Delhi - CV, EC, EE & ME (Validity: 2019-20 to 2021-22)**

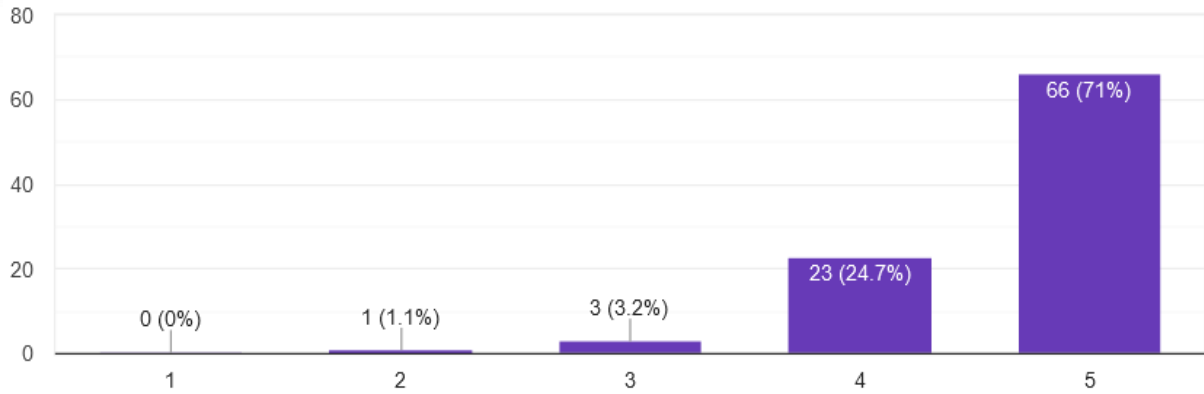

**Question: Resource persons explained the concepts clearly during sessions**

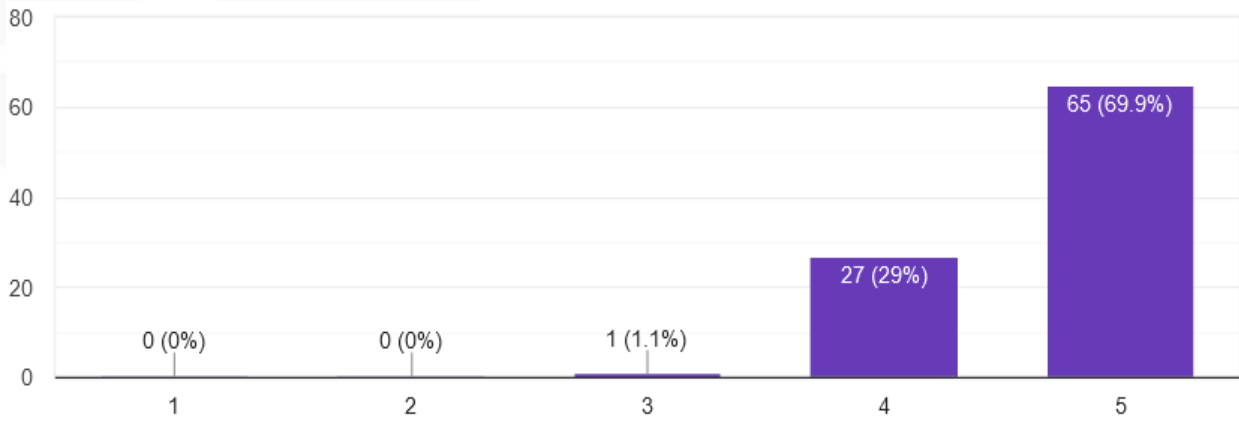

**ATME COLLEGE OF ENGINEERING**

13th Kilometer, Mysore-Kanakapura-Bangalore Road, Mysore - 570 028 P: 0821-2593335 F: 0821-2593328

Email : info@atme.in Web : www.atme.in



# ATME

## College of Engineering



# NBA

ACCREDITED

Affiliated to VTU, Belagavi; Approved by AICTE, New Delhi and Recognised by Government of Karnataka  
Programs accredited by NBA, New Delhi - CV, EC, EE & ME (Validity: 2019-20 to 2021-22)

### **Webinar on “How to Write Proposals for Funding”**

ATME College of engineering had organised a webinar on “*How to Write Proposals for Funding*” on 30<sup>th</sup> December 2020. The webinar was conducted in MS Teams platform and a total of 151 participants from ATMECE and other institutions had participated for the event. The webinar was scheduled at 3 PM with formal introduction about the webinar followed by brief introduction of resource person.

Dr. Prakash K R, Professor, Department of Mechanical Engineering, NIE, Mysuru was kind enough to accept our invitation as resource person to educate the faculty members on writing proposal for funding.

Dr. Bhagyashree S R, Dean-Research and Professor, ATMECE and Dr. Parthasarathy L, IEEE student branch counsellor, Professor and Head, Dept. of EEE ATMECE, were the convenors of the program.

Dr. Md Nadeem M, Asst. professor, Dept of ME, Mrs. Nasreen Fathima, Asst. professor, Dept of CSE and Mr. Vinod Kumar P, Asst. professor, Dept of EEE Organised and hosted the webinar.

Dr. Prakash K R discussed about grant proposal or application which is a document or set of documents submitted to an organization with the explicit intent of securing funding for a research project. Sir empathized on identifying the needs and focus in order to develop a full-blown research agenda.

Sir provided sources of information about granting agencies and grant programs. Sir discussed about writing grant proposals, assume that you are addressing a reviewer who is knowledgeable in the specified field and clear define research questions along with proper solution. Final decisions about which proposals are funded often come down to whether the proposal convinces the reviewer that the research project is well planned and feasible and whether the investigators are well qualified to execute it.

#### **ATME COLLEGE OF ENGINEERING**

13<sup>th</sup> Kilometer, Mysore-Kanakapura-Bangalore Road, Mysore – 570 028 P : 0821-2593335 F: 0821-2593328

Email: [info@atme.in](mailto:info@atme.in)

Web : [www.atme.in](http://www.atme.in)



# A T M E

## College of Engineering



# NBA ACCREDITED

Affiliated to VTU, Belagavi; Approved by AICTE, New Delhi and Recognised by Government of Karnataka  
**Programs accredited by NBA, New Delhi - CV, EC, EE & ME (Validity: 2019-20 to 2021-22)**

Dr. Prakash K R answered the questionnaires raised by the participants and gave them suggestions providing information related to research proposal for various government agencies etc.

Dr. Md Nadeem M concluded the webinar by giving vote of thanks to Dr. Prakash K R, Management of ATMECE, Principal, Dean, HODs and to all the participants.

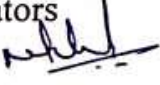
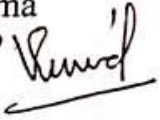
Organizing Coordinators  
Dr. Md. Nadeem M   
Mrs. Nasreen Fathima  
Mr. Vinod Kumar P 



**ATME COLLEGE OF ENGINEERING**

13<sup>th</sup> Kilometer, Mysore-Kanakapura-Bangalore Road, Mysore – 570 028 P : 0821-2593335 F: 0821-2593328

Email: [info@atme.in](mailto:info@atme.in)

Web : [www.atme.in](http://www.atme.in)

Report on  
**Three days National level FDP on “Intellectual Property Rights in  
Engineering Educations”**

Department of Electronics and Communication Engineering has organized Three days National level FDP on “Intellectual Property Rights in Engineering Educations” from 29<sup>th</sup> July to 31<sup>st</sup> July.

The FDP was targeted for teaching fraternity of various engineering institutions.

**Title:** “Intellectual Property Rights in Engineering Educations”.

**Platform:** MS Team

**Registration Charge:** 100/- Rs.

**Convener:** Dr. Yathisha L Associate Professor, Dept. of ECE, ATMECE, Mysuru.

**Coordinators:** Mrs. Shalini V S, Mr. Girish M, Ms. Anupama Shetter, , Mr. Manjunath K Assistant Professors, Dept. of ECE, ATMECE, Mysuru.

All the sessions were live streamed in the ATMECE official Youtube channel

Intellectual property (IP) is a term that describes a number of distinct types of intangible assets. IP protection allows a rights holder to exclude others from interfering with or using the property right in specified ways. The main forms of IP are patents, copyrights, trademarks, and trade secrets. Each type of IP protection is different, varying in the subject matter that can be covered, timeframe of protection, and total expense. Although some inventions may be covered by multiple types of IP protection, it is important to consider a number of business and legal factors before selecting the best protection strategy. Some technologies require strong IP protection to commercialize, but unnecessary costs can derail bringing a product to market. IP departments of organizations weigh these various considerations and perform essential IP protection functions. This primer introduces researchers to the main forms of IP and its legal aspects.

A total of **64 participants** from various Engineering institutes across the Karnataka had registered for the FDP.

The poster of the event is shown below.

**A T M E**  
College of Engineering

In association with Karnataka State Council for Science & Technology(KSCST), IISc, Bengaluru

Organises  
**Three Days National Level FDP**  
On  
**"Intellectual Property Rights in Engineering Educations"**

**Keynote Address:**  
**Mr. H Hemanth Kumar**  
Executive Secretary,  
Karnataka State Council for Science and Technology (KSCST),  
IISc Campus, Bengaluru.

**Dr. Sanjeeva Kumar Majumdar**  
Manager-IPR, Start Up & Incubation  
National Research Development Corporation (NRDC), New-Delhi  
Date: 29th July 2020  
Timings: 10.30AM-12.30PM  
Topics: Introduction to IPR Spectrum and Indian Patent System

**Mr. Santosh M Nejjakar**  
Chief Coordinator IP Cell,  
DBIT, Bangalore  
Date: 29th July 2020  
Timings: 2.00PM-4.00PM  
Topics: Introduction to Patent and The Semi-Conductor Integrated Circuit Layout Design act

E-Certificates will be provided to the registered Participants.

Further Details Contact:  
Mrs. Shalini V S: 8553252589 | Mr. Girish M: 9964406840  
Registration Fee: Rs. 100/-

**A T M E**  
College of Engineering

**Dr. Sarsija Pedhanabhan**  
Patent Agent and Advisor Member for PIC,  
Karnataka State Council for Science and Technology, Bengaluru  
Date: 30th July 2020  
Timings: 10.00AM-12.00PM  
Topics: Patent Search and Drafting Claims

**Mr. B. Vivek Anand Sagar**  
Consultant and IPR Attorney,  
Patent Information Centre,  
Karnataka State Council for Science and Technology, Bengaluru.  
Date: 30th July 2020  
Timings: 2.00PM-4.00PM  
Topics: Copyrights and filing procedure

**Mr. Nagarjun M G**  
Project Associate, Patent Information Center,  
Karnataka State Council for Science and Technology, Bengaluru.  
Date: 31st July 2020  
Timings: 10.00AM-12.00PM  
Topics: Industrial Designs

**Mr. Kodandaram M.G.**  
IRS Retd, National Academy of Customs, Indirect Taxes and Narcotics, Bengaluru.  
Date: 31st July 2020  
Timings: 2.00PM-4.00PM  
Topics: IPR Law and Cyber Interface

**Chief Patron:**  
Mr. L Arun Kumar  
Chairman, ATMECE, Mysuru  
Mr. K. Shivashankar  
Secretary, ATMECE, Mysuru  
Mr. R. Veeresh  
Treasurer, ATMECE, Mysuru  
**Patron:**  
Dr. L Basavaraj  
Principal, ATMECE, Mysuru

**Chief Coordinator:**  
Dr. Mahesh P K  
HOD, Dept. of ECE,  
ATMECE, Mysuru

**Convener:**  
Dr. Yathisha L  
Associate Professor,  
Dept. of ECE, ATMECE, Mysuru

**Faculty Coordinators:**  
Shalini V S  
Asst. Professor, Dept. of ECE  
Girish M  
Asst. Professor, Dept. of ECE  
Anupama Shetter  
Asst. Professor, Dept. of ECE  
Manjunath K  
Asst. Professor, Dept. of ECE

NEET details:  
Account Name:  
ACADEMY FOR TECHNICAL AND MANAGEMENT EXCELLENCE  
Account Number: 0518101054379  
IFSC Code: CNRB0004966  
Bank: Canara Bank

Register here  
  
<https://forms.gle/iRAuVnMovofYX5g6>

Resource persons from NRDC New Delhi, KSCST Bangalore & DBIT Bangalore were invited as speakers for the FDP.

**Day 1: 29/07/2020**

**Session 1: 10:30 AM to 12:30 PM**

**Resource person: Dr. Sanjeeva Kumar Majumdar**, Manager in StartUp Activities & Intellectual Property Division of National Research Development Corporation(NRDC), New Delhi

**Topic: Introduction to IPR Spectrum & Patent System**

The FDP started at **9.50 AM**, Dr. Basavaraj L, Principal, ATMECE welcomed the guests and the participants. From 10.00 AM - 10.20 AM Mr. H Hemanth Kumar Executive Secretary, KSCST delivered the key note address. The resource person **Dr. Sanjeeva Kumar Majumdar** Manager IPR, NRDC, New Delhi started the session at 10.30 AM. Topics covered in the session are Introduction to IPR Spectrum and Indian Patent System, importance of IPR & the different types of patent application in India.

Some of the screenshots of the sessions are

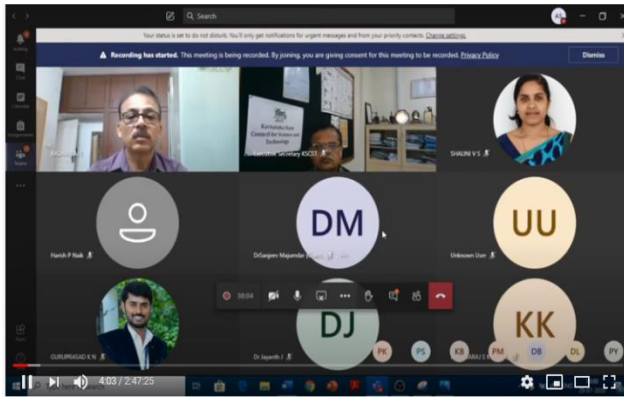

Youtube video link of the session: <https://www.youtube.com/watch?v=vD4RZTwf4sQ&t=7241s>

**Day 1: 29/07/2020**

**Session 2:** 02:00 PM to 04:00 PM

**Resource person:** Mr. Santhosh M Neजार, DBIT, Bangalore

**Topic:** Introduction to Patent & The semiconductor Integrated Circuit Layout Design act

Mr. Santhosh M Neजार, DBIT, Bangalore started the session at 02.00 PM by briefing the concept of patent. The topics which was covered in the session includes The topics which was covered in the session includes importance of IPR in Engineering Education, history of patent & covered the concept of copyright. Some of the screenshots of the sessions are

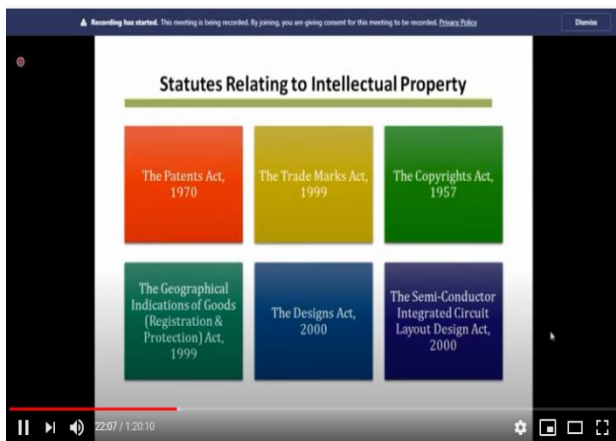

Youtube video link of the session: [https://www.youtube.com/watch?v=gcuS\\_O\\_gvMo&t=3649s](https://www.youtube.com/watch?v=gcuS_O_gvMo&t=3649s)

**Day 2: 30/07/2020**

**Session 1: 10:00 AM to 12:00 PM**

**Resource person: Dr. Sarsija Padhanabhan, KSCST, Bangalore**

**Topic: Patent Search & Drafting Claims**

Dr. Sarsija Padhanabhan, KSCST, Bangalore started the session at 10.00 AM by introducing the concept of patent. The topics which was covered in the session includes information regarding patents & the process to be followed to apply for patent. Some of the screenshots of the session are as shown below.

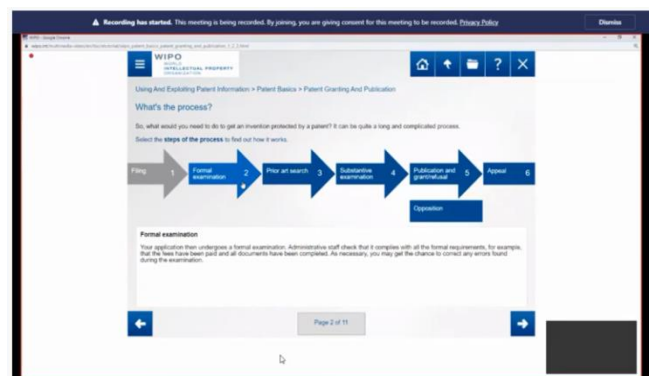
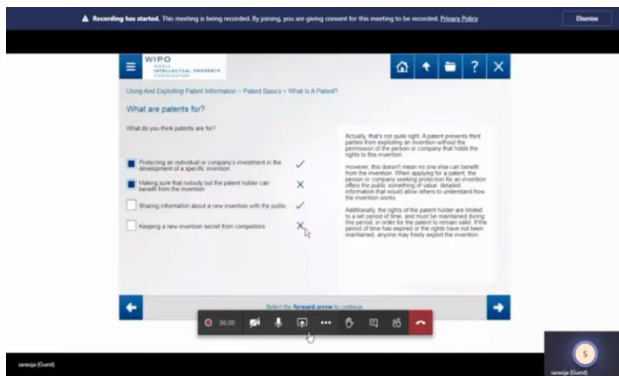

Youtube video link of the session: [https://www.youtube.com/watch?v=Ij\\_DPpLfQIA&t=2119s](https://www.youtube.com/watch?v=Ij_DPpLfQIA&t=2119s)

**Day 2: 30/07/2020**

**Session 2: 02:00 PM to 04:00 PM**

**Resource person: Mr. B. Vivek Anand Sagar, KSCST, Bangalore**

**Topic: Copyrights & filing procedure**

Mr. B. Vivek Anand Sagar, KSCST, Bangalore started the session at 02.00 PM. The topics which was covered in the session includes the concept of copyrights, plagiarism, citation & process of filing the patent. Some of the screenshots of the session are as shown below.

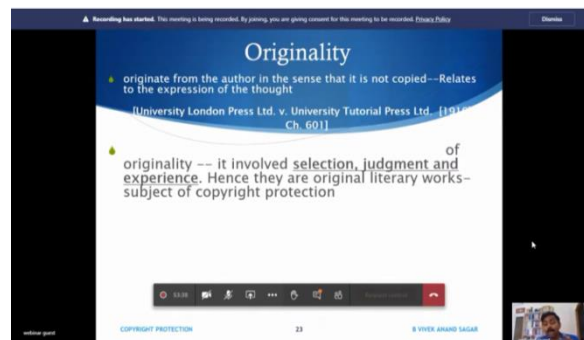

Youtube video link of the session: <https://www.youtube.com/watch?v=zicfy7nChEo&t=2527s>

**Day 3: 31/07/2020**

**Session 1: 10:00 AM to 12:00 PM**

**Resource person: Mr. Nagarjun M G, KSCST, Bangalore**

**Topic: Industrial Designs**

Mr. Nagarjun M G, KSCST, Bangalore started the session at 10.00 AM. The topics covered in the session includes the basics of design & the different techniques to be used & the parameters to be considered while designing the product. Some of the screenshots of the session are as shown below.

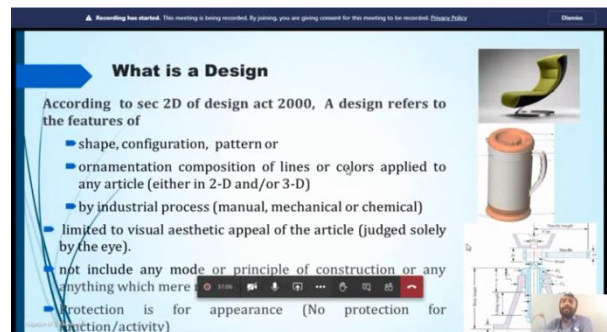

Youtube video link of the session: <https://www.youtube.com/watch?v=pHBGZzTf04k>

**Day 3: 31/07/2020**

**Session 2: 02:00 PM to 04:00 PM**

**Resource person: Mr. Kodandaram M G, IRS Retd, Bangalore**

**Topic: IPR Law & Cyber Interface**

Mr. Kodandaram M G, IRS Retd, Bangalore started the session at 02.00 PM by introducing the concept of different IPR law. The topics which was covered in the session includes concepts of Intellectual property & the cyber interface between producer & consumer. Some of the screenshots of the session are as shown below.



Youtube video link of the session: [https://www.youtube.com/watch?v=I6M\\_2HSAjQg&t=6214s](https://www.youtube.com/watch?v=I6M_2HSAjQg&t=6214s)



Our sincere thanks to **Management**, ATME College of Engineering, **Dr. L. Basavaraj**, the Principal, ATMECE & **Dr. Mahesh P.K.**, HOD, Dept. of ECE for their continuous encouragement and the support for the successful completion of the Three days National level FDP on “Intellectual Property Rights in Engineering Educations”



# A T M E

College of Engineering

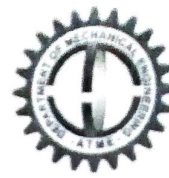

## Department of Mechanical Engineering

Date:10-08-2020

To,  
The Principal,  
ATMECE,  
Mysore-570028

Respected Sir,

**Subject: Permission to conduct National Level online Faculty Development Program reg.**

We are planning to organize a National level 3-day online Faculty Development Program on AICTE Exam Reforms. The FDP is planned to be conducted from 27-08-2020 to 29-08-2020. The resource persons are the Faculty members from our Institution and They are; Prof. Ravikumar S, Dr. Chethan S, & Dr. Md. Nadeem from Dept. of ME, Prof. Raghavendra L, from Dept. of EEE, Prof. Sunitha Patel & Prof. Nasreen Fathima from Dept. CSE and Prof. Abhilash G, from Dept. of EC. The FDP will be conducted online using Microsoft Teams platform. The registration will be free and participants will receive an e-certificate after attending three days FDP.

In this regard we request your permission to conduct the same. The detailed report of the FDP will be submitted to you after the conduction of the program.

Thanking you Sir,

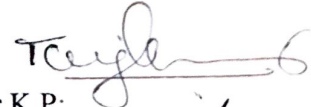
Prof. Thejkumar J: 

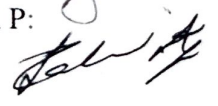
Prof. Pavan Kumar K P: 

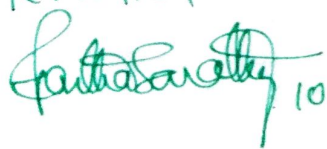
Permitted  
 10.8.2020

Yours

  
HoD 10/8/2020

ATME COLLEGE OF ENGINEERING

13th Kilometer, Mysore-Kanakapura-Bangalore Road, Mysore - 570 028 P: 0821-2593335 F: 0821-2593328

Email : info@atme.in Web : www.atme.in



## Department of Mechanical Engineering



### 3 Days National Level Faculty Development Program on **AICTE Exam Reforms: An Overview**

**Date:**  
27<sup>th</sup>, 28<sup>th</sup> & 29<sup>th</sup> AUGUST 2020

#### About the FDP:

Worldwide adaptation of Outcome-Based Education framework and enhanced focus on higher-order learning and professional skills necessitates paradigm shift in traditional practices of curriculum design, education delivery and assessment. In recent years, worldwide sweeping reforms are being undertaken to bring about essential changes in engineering education in terms of what to teach and how to teach and how to assess. Examinations/student assessments play a very important role in deciding the quality of education.

#### Topic to be covered in the FDP

Date	Session - I 10.00 a.m – 11.30 a.m	Session - II 12.00 p.m – 1.30 p.m
27 AUG 2020	Introduction to AICTE Exam Reforms	Need for OBE and 3 concepts for implementing OBE

Date	Session - I 10.00 a.m - 11.30 a.m	Session - II 12.00 p.m - 1.30 p.m
28 AUG 2020	Understanding Graduate Attributes and Process of adopting OBE framework	Bloom's Taxonomy and its use in Designing Assessments
29 AUG 2020	Use and writing of Assessment Rubrics	Bringing about changes in laboratory experiments

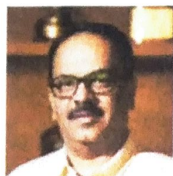

Chief Patron  
Sri. L Arun Kumar  
Chairman



Principal  
Dr. L Basavaraj



Organizing Chair  
Dr. Srinivasa K  
Prof & Head ME

## Resource Persons



Prof. Ravi Kumar S



Prof. Nasreen Fathima



Prof. Chethan S



Prof. Md. Nadeem



Prof. Raghavendra L



Prof. Sunitha Patel



Prof. Abhilash G

## Event Coordinators



Prof. Thejkumar J  
82964 18364



Prof. Pavan Kumar K P  
97393 69963

All Participants Will Receive E - Certificates Upon Completion

**Registration is Free**

To register: <https://forms.gle/4Y3ttKEvQh6VtyNZ6>

## Department of Mechanical Engineering

### A Report on National Level 3 Day Online Faculty Development Program on AICTE Exam Reforms-An Overview.

Mechanical Engineering department had organised a National level 3 Day Online FDP on AICTE Exam Reforms-An Overview from 27<sup>th</sup> Aug to 29<sup>th</sup> Aug 2020. Participants from various states have registered for the program. The Resource persons were the faculty members from various Engineering Departments of ATMECE. The registration was free and the Participants were issued an e-certificate upon successful completion of all the three days program. The FDP was inaugurated by our honourable Principal Dr. Basavaraj L. In his inaugural address he has highlighted the necessity of exam reforms in the back ground of New Education Policy implemented by the Ministry of Higher Education, Govt. of India. He has expressed his happiness about the interest shown by all the Participants across India and appreciated the efforts of the coordinators in organising such a useful FDP.

The session wise details are as follows;

#### Day 1:

Inaugural function followed by **Session 1:** From 10:00 am to 11:30 am,

**Resource Person:** Prof. Ravikumar S, Assoc. Prof., Dept. of ME, ATMECE, Mysuru.

**Topics covered:** - Introduction to AICTE Exam reforms, Three Key elements of student learning, Key drivers of Examination reforms and key issues addressed by the Examination Reforms Report Nov. 2018.

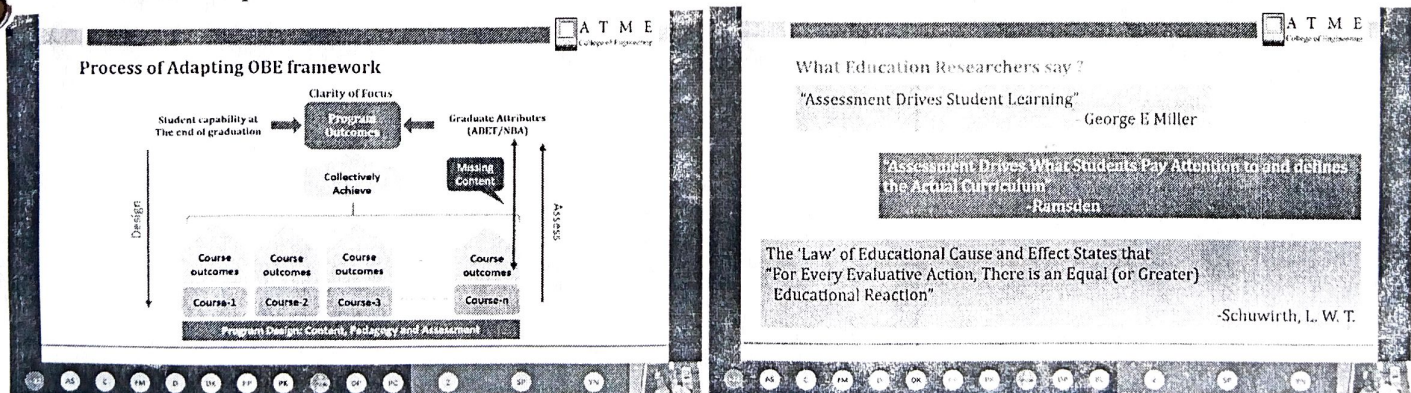

*Prof. Ravi Kumar S presenting the topic on Introduction to AICTE Exam Reforms*



A T M E

College of Engineering

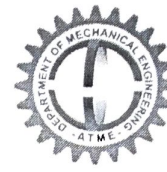

## Department of Mechanical Engineering

**Session 2:** From 12:00 noon to 1:30pm

**Resource person:** Prof. Abhilash G, Asst. Prof. Dept. of ECE, ATMECE, Mysuru

**Topics covered:** Need for Outcome Based Education and three concepts for Implementing OBE, OBE Philosophy, curriculum Design, Traditional education v/s OBE, Elements of OBE, three concepts to be understood for easy implementation of OBE.

3 Day Faculty Development Program on AICTE Exam Reforms: An Overview

A T M E  
College of Engineering

ISO 9001:2015

### Need for OBE

- Need – To remain competitive on a globally adapted framework

Adaptation of OBE framework will ensure that there are essential changes in engineering education in terms of

- What we teach (**Content**)
- How we teach (**Knowledge Delivery**)
- How we assess (**Student Learning**)

August 28<sup>th</sup>, 2020

*Prof. Abhilash G presenting the topic on Need of OBE*

### Day 2:

**Session 1:** From 10:00 am to 11:30 am,

**Resource Persons:** Prof; Sunitha Patel, Asst. Prof. Dept. of CSE, ATMECE, Mysuru

Prof: Nasreen Fathima, Asst. Prof. Dept. of CSE, ATMECE, Mysuru.

**Topics Covered:** Understanding Graduate attributes, Components of Program Outcomes, Process of adopting OBE frame work, understanding Course Outcomes (COs), Characteristics and Structure of CO, Guidelines for writing COs.

## Department of Mechanical Engineering

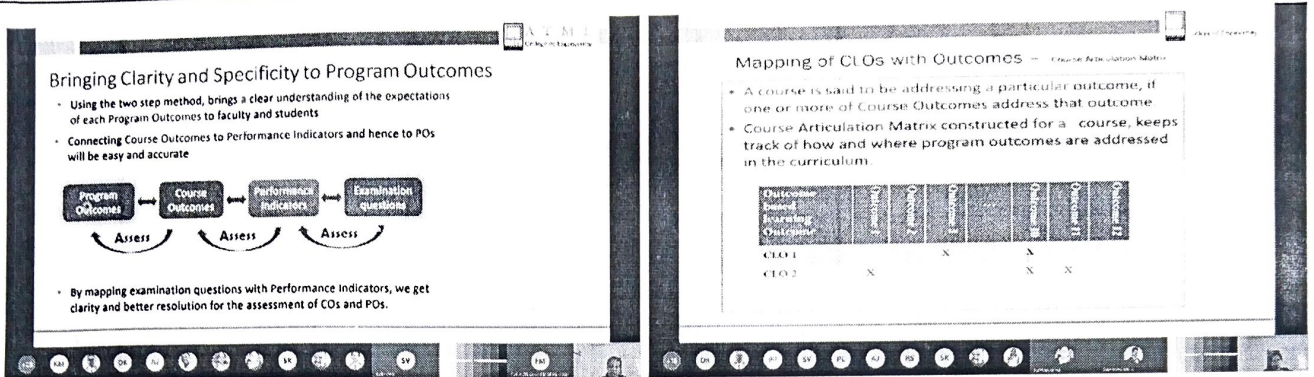

**Bringing Clarity and Specificity to Program Outcomes**

- Using the two step method, brings a clear understanding of the expectations of each Program Outcomes to faculty and students
- Connecting Course Outcomes to Performance Indicators and hence to POs will be easy and accurate

**Mapping of CLOs with Outcomes**

- A course is said to be addressing a particular outcome, if one or more of Course Outcomes address that outcome
- Course Articulation Matrix constructed for a course, keeps track of how and where program outcomes are addressed in the curriculum.

Outcome Based Learning Outcome	Outcome 1	Outcome 2	Outcome 3	Outcome 4	Outcome 5	Outcome 6
CLO 1			X		X	
CLO 2	X				X	X

*Prof. Sunitha Patel & Prof. Nazreen Fathima presenting on the occasion on FDO AICTE Exam Reforms Day-2*

**Session 2:** 12:00 noon to 1:30pm.

**Resource Person:** Prof. Raghavendra L, Assoc. Prof., Dept. of EEE, ATMECE, Mysuru.

**Topics Covered:** Blooms Taxonomy and its use in designing assessments, Action verbs for assessments, Assessment planning, examples of typical questions for each BTL.

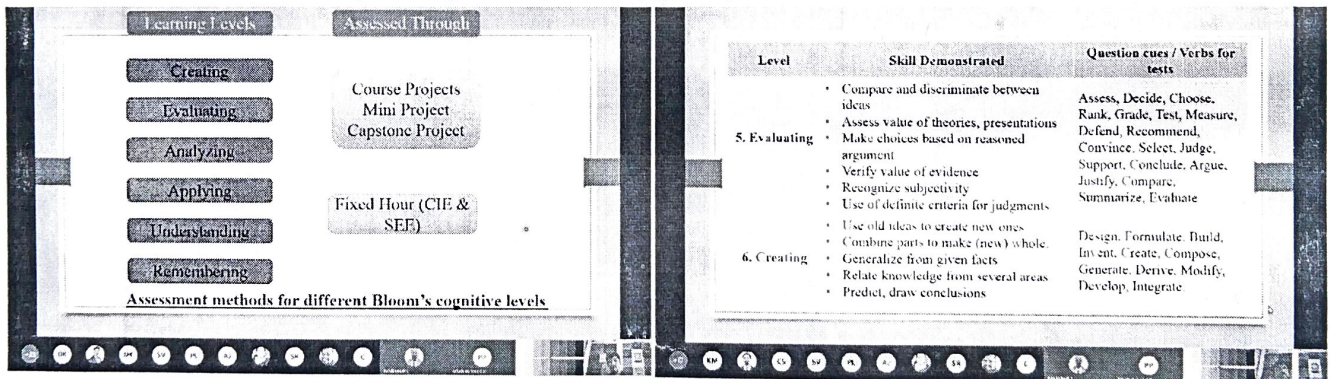

Level	Skill Demonstrated	Question cues / Verbs for tests
5. Evaluating	<ul style="list-style-type: none"> <li>Compare and discriminate between ideas</li> <li>Assess value of theories, presentations</li> <li>Make choices based on reasoned argument</li> <li>Verify value of evidence</li> <li>Recognize subjectivity</li> <li>Use of definite criteria for judgments</li> </ul>	Assess, Decide, Choose, Rank, Grade, Test, Measure, Defend, Recommend, Convince, Select, Judge, Support, Conclude, Argue, Justify, Compare, Summarize, Evaluate
6. Creating	<ul style="list-style-type: none"> <li>Use old ideas to create new ones</li> <li>Combine parts to make (new) whole</li> <li>Generalize from given facts</li> <li>Relate knowledge from several areas</li> <li>Predict, draw conclusions</li> </ul>	Design, Formulate, Build, Invent, Create, Compose, Generate, Derive, Modify, Develop, Integrate

*Prof. Raghavendra L presenting on the occasion on FDO AICTE Exam Reforms Day-2 on Blooms Taxonomy*

### Day 3:

**Session 1:** From 10:00 am to 11:30 am,

**Resource Person:** Prof. Md. Nadeem, Asst. Prof., Dept. ME, ATMECE, Mysuru.

Prof. Chethan S, Asst. Prof., dept. ME, ATMECE, Mysuru.

**Topics Covered:** Use and Writing of Assessment Rubrics, understanding task description, Scales, dimensions and descriptors, developing rubrics, examples of Rubrics, Bringing about Changes in lab experiments, Categorisation of experiments, Reforms in Laboratory experience.

**Department of Mechanical Engineering**

**Session 2:** From 2:00 noon to 1:30 pm

**Resource Person:** Prof. Chethan S, Asst. Prof., dept. ME, ATMECE, Mysuru.

Topics covered: Improving Structure and Quality of Assessment, Assessment Strategy for OBE, Innovative Educational experiences to teach and assess, Assessing Higher order abilities and Professional skills.

Valedictory function was held immediately after the second session, Participants were asked to give their feedback on the FDP and few of them expressed that it was a useful one and thanked the organising committee for organising it in a very good manner. Prof. Devaraj MR, Assoc. Prof., Dept. of ME rendered Vote of thanks. And all participants were requested to fill the feedback form in google forms, upon submission of the same they were issued the e-certificate.

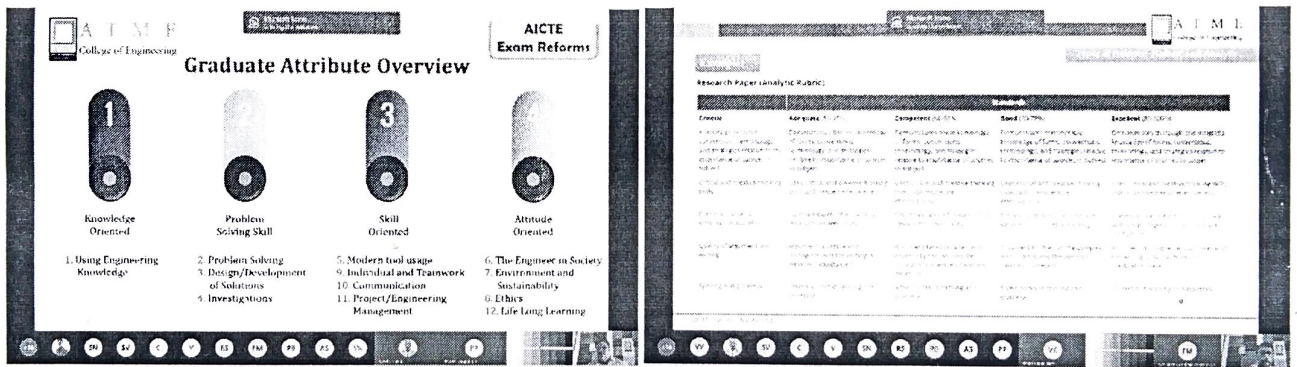

*Dr. Chethan S and Dr. Md. Nadeem M presenting on the occasion on FDP AICTE Exam Reforms Day-3 on Assessment Rubrics*

**Feed Back & Inference:**

Feed back forms are attached along with the report for the reference. It is found from the feedback for all the three days on the FDP on AICTE Exam Reforms that more than 70% of the participants felt that the content of the FDP Covers contemporary topics/ issues related to Examination reforms need to be Inculcated in our Education System, and the Program is well Structured and objective of the FDP met effectively.

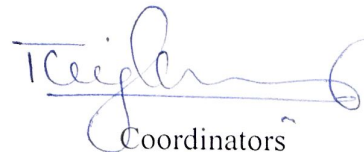

Coordinators

(Prof. Thejkumar J & Prof. Pavan Kumar KP)





# A T M E

College of Engineering



9001:2015

## Department of Mechanical Engineering

### You Tube Links of the videos @ ATMECE official:

Day1: Session1: <https://youtu.be/dpqxWT9AYjQ>

Session2: [https://youtu.be/yRYU7\\_DLvHw](https://youtu.be/yRYU7_DLvHw)

Day2: Session1 & 2: <https://youtu.be/3V4JG2FK3Jo>

Day3: Session1: <https://youtu.be/yymQ9--xBf8>

Session2: [https://youtu.be/pDh0X\\_Vc814](https://youtu.be/pDh0X_Vc814)

### Google drive Links for the FDP Resources:

<https://drive.google.com/drive/folders/10aVyrlpJpXDCKX8cE305pqs-KtY3-NC5?usp=sharing>

*A. Pallavi*

**H.O.D.**

Department of Mechanical Engineering  
ATME College of Engineering, Mysuru

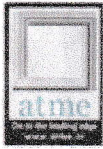

Dr. Srinivasa K  
Professor and Head

Date:15.10.2020

Report  
on  
**Latest Technologies in Manufacturing  
&  
Area of focus for Today's Engineering students"**

National Webinar conducted on 14<sup>th</sup> October 2020 through online on the topic "Latest Technologies in Manufacturing & Area of focus for Today's Engineering students" was organized with the intension to give the awareness and Knowledge on latest trends in manufacturing and its advancements also areas to focus in latest manufacturing techniques and methods to the final year students (2020-2021).

The invited speaker **Mr.NanjundaNaika from BEML**, addressed our final year students with the above said topic and expressed best wishes to Final year students at the end of the session.

Mr.Devaraj M R welcomed the speaker, Professors, Deans, Faculty and all the participants to the webinar. Mr.Yashwanth N rendered the vote of thanks to Speaker and all participants.

This event was coordinated by:

Mr.Devaraj M R,

Dr.Mohanakumara K C

Mr. Yashwanth N and

Mr.Niranjan kumar V S.

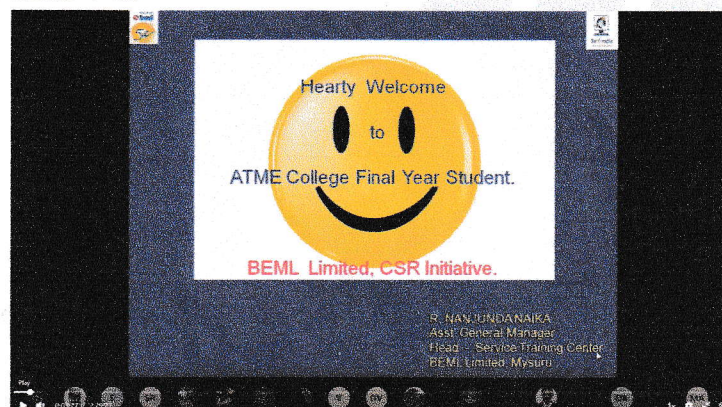

Speaker started presenting the lecture on  
Latest Technologies in Manufacturing & Area of focus for Today's Engineering students"

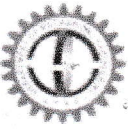
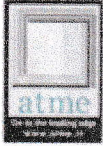

**DEPARTMENT OF MECHANICAL ENGINEERING**

**Dr. Srinivasa K**  
**Professor and Head**

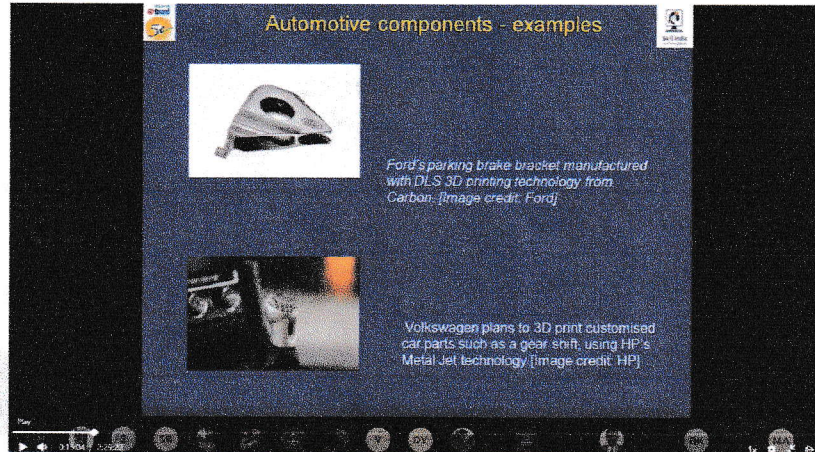

Speaker explaining with various examples

**Speaker:**

**Mr. Nanjunda Naika**

Name: R. NANJUNDA NAIKA

Present Designation: Asst. General Manager,

M/s BEML Ltd. Mysuru

Qualification: Bachelor of Engineering, SJCE, Mysuru.

Experience: 26 Years. ISTD Membership No: N- 415 / 2019

Date: 14<sup>th</sup> October 2020

Time: 3.00 PM

Department of Mechanical Engineering  
ATME College of Engineering, Mysuru-28

HOD  
Department of Mechanical Engineering  
ATME College of Engineering  
Mysuru - 570028



# A T M E

College of Engineering

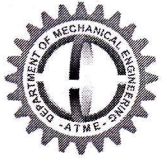

## Department of Mechanical Engineering

To,  
The Principal  
ATMECE,  
Mysuru

Date: 08.10.2020

Through, **Head of the Department**, Department of Mechanical Engg.

Department of Mechanical engineering is planning to conduct National webinar on **“Latest Technologies in Manufacturing & Area of focus for Today’s Engineering Students”** on **14<sup>th</sup> October 2020** for final year students with the intension to provide an insight on latest trends in Manufacturing and giving awareness on areas to look after which helps to shape their career.

In this connection requesting you to kindly give permission to conduct this webinar on the above said date.

Thanking you sir.

*Forwarded to Principal for kind approval.*

*KS*  
*9/10/2020*  
**H.O.D.**

Department of Mechanical Engineering  
ATME College of Engineering, Mysuru

Yours faithfully

*Devaraj MR*  
**(DEVARAJ MR)**

Department of Mechanical Engineering  
ATME College of Engineering, Mysuru

*Approved*  
*[Signature]*  
*8/10*

ATME COLLEGE OF ENGINEERING

13th Kilometer, Mysore-Kanakapura-Bangalore Road, Mysore - 570 028 P: 0821-2593335 F: 0821-2593328  
Email : info@atme.in Web : www.atme.in



**A T M E**  
College of Engineering

**Department of  
Mechanical Engineering**  
Accredited by NBA 2019-20 to 2021-22

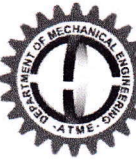

**National Webinar on  
Latest Technologies in Manufacturing  
&  
Area of Focus for Today's Engineering Students**

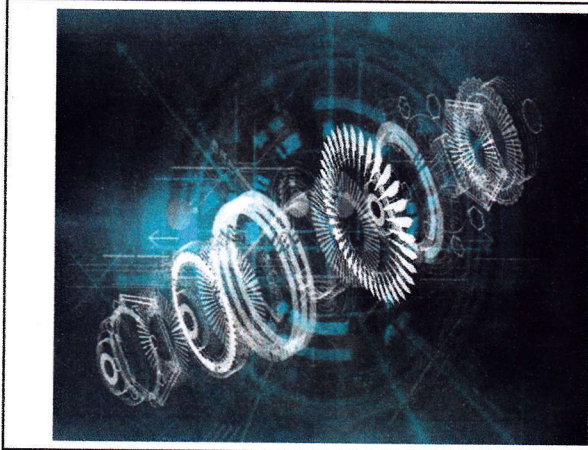

**Date : 14<sup>th</sup> October 2020  
Time :3.00 PM-4.00 PM**

**Resource Person : R. NANJUNDA NAIKA**  
Asst. General Manager  
Head – Service Training Centre  
**M/s BEML Limited**  
Truck Division  
Mysuru

**Co-ordinators**

**Prof. Devaraj M R,**  
Assoc. Prof., Dept. Mechanical Engineering  
**Dr.Mohanakumara K C,**  
Asst. Prof., Dept. Mechanical Engineering  
**Prof.Niranjan Kumar V S,**  
Asst. Prof., Dept. Mechanical Engineering  
**Prof.Yashwanth N,**  
Asst. Prof., Dept. Mechanical Engineering

**Convener**  
**Dr. Srinivasa K**  
Prof. & Head  
Dept. Mechanical Engg.  
ATME College of Engineering

Registration  
<https://forms.gle/2u8C7ctS2pb8dTsp7>  
E-Certificates will be issued to those participants who will attend the entire session and fill the feedback form

**For information please Contact:**  
**Prof. Devaraj M R-**  
**9972322811**  
**Prof: Yashwanth N-**  
**9663994514**



Name	: R. NANJUNDA NAIKA
Present Designation	: Asst. General Manager, M/s BEML Ltd.
Qualification	: Bachelor of Engineering, SJCE, Mysuru.
Experience	: 26 Years.
ISTD Membership No.	: N- 415 / 2019

**Work experience** : 26 years of 360 degree experience in a major engineering Industry under Ministry of Defence.

- Production Planning and scheduling.
- Import and export Management.
- Cost estimation.
- Assembly line
- Research & Development.
- Marketing – Service function at a key regional office.
- Head – Service Training Center.
- New product Management. Business dealings with MNC companies/Collaborators.
- Involved in Road Map and implementation of SAP and PLM systems.
- Under Skill India initiative, more than 8,000 Man days training during the last 3 years.

**Other functions** :

- Lead Auditor : ISO 9000 QMS, Trained Six Sigma Black Belt.
- Kaizen Movement, Quality Circle Activities: Lead teams to win many awards.
- Lean Manufacturing.
- Knowledge sharing on various Management topics.

**Professional Forums engagements** :

- Worked as committee Member for 2 terms in IIMM, Mysuru Chapter.
- Worked as Joint Secretary for one term in IIPE – Mysuru Chapter
- FIE in IIEE., Life member ISTD., Undergone Train the Trainer ( TOT ) at ISTD, New Delhi.
- Youth Hostel : Participated in “ Discover Karnataka “ 1500 Kms cycle expedition.
- Undergone Army Attachment Camp as part of NCC Senior Division during college.

**CSR Activities** :

- Guided MBA Projects and Master engineering Degree projects.
- Mentoring to Engineering Graduates, Diploma and ITI during Internship/ Apprentice program.

**Vision for ISTD Mysuru** :

**“ Make ISTD Mysuru Chapter Number ONE Chapter in India”**

# Feedback on National Webinar on- Latest Technologies in Manufacturing & Area of Focus for Today's Engineering Students

57 responses

Publish analytics

## Name

57 responses

Karthik

Deepak M V S

HarshaVardhana M S

Dr.Srinivasa.K

Dr.Raviprakash.M

Peter A X

Raghunandan M S

SRIPADA SHREEVALLABHA

Prasad H Nayak



### Institute/Organization

57 responses

ATME College Of Engineering, Mysuru

GSSSIETW, Mysuru

VVIET

Dayanandasagar Academy of Technology & Management

Mysore college of engineering and management

ATME College of Engineering

RNS Institute of Technology

Tontadarya College of Engineering Gadag

Government engineering college/ Ramanagara

### Department

57 responses

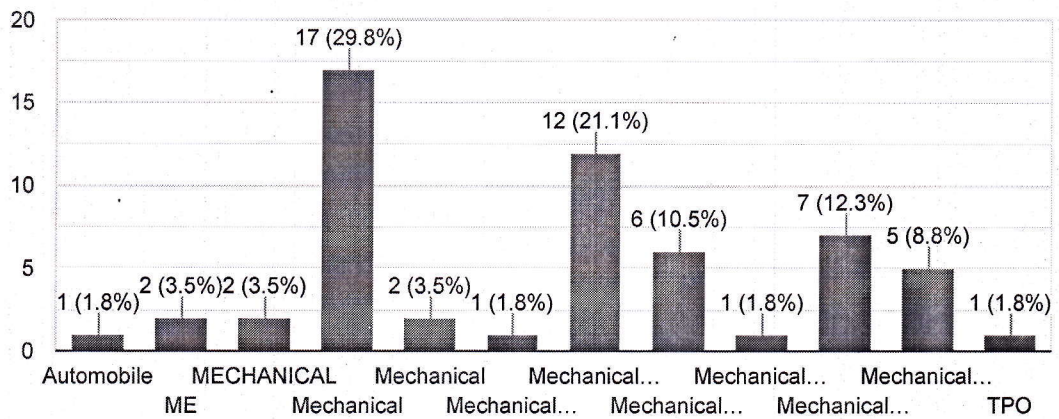



Mobile No.

57 responses

9844671522

9632216962

8105995636

7760584212

704401042

8618813262

9945045415

9686276032

+919482134913



The Speaker provided adequate information and helped the participants to understand about the topic delivered

57 responses

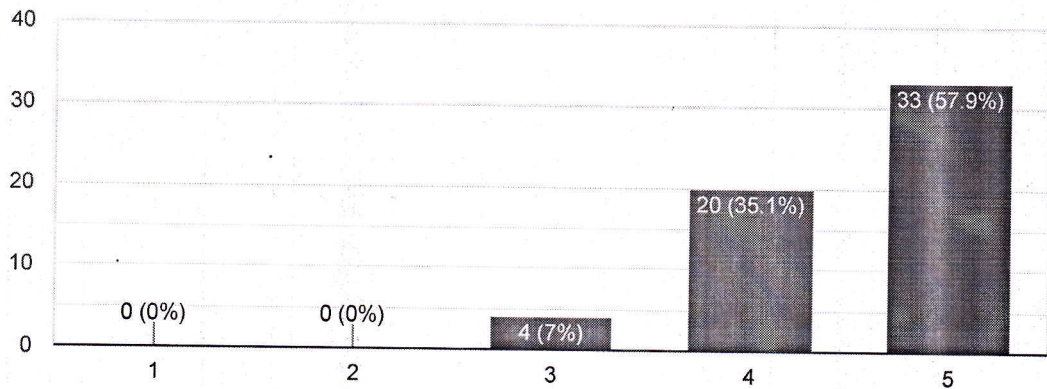

The Program is well Structured and objective of the webinar met effectively

57 responses

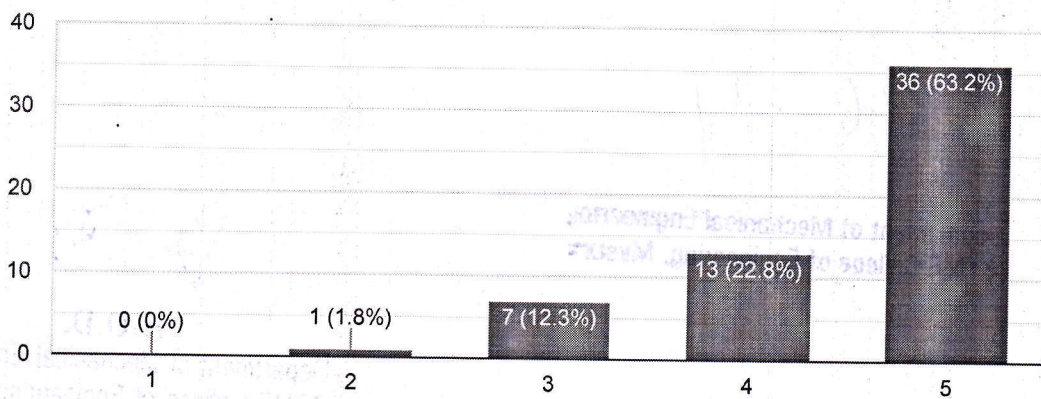

### Any other Comments or Suggestions

37 responses

No

Nil

excellent

The session was good.. We want more sessions.. Thank you

Kindly keep on providing such resourceful contents.

Thanks for inviting us...

NIL

Please make sure that there is no noise from external sources for the smooth conduct of the webinar

No. thanks. .

This content is neither created nor endorsed by Google. [Report Abuse](#) - [Terms of Service](#) - [Privacy Policy](#)

Google Forms

Department of Mechanical Engineering  
ATME College of Engineering, Mysuru

H.O.D.  
Department of Mechanical Engineering  
ATME College of Engineering, Mysuru



## INFERENCE

### National Webinar on “Latest Technologies in Manufacturing & Area of focus for today’s Engineering students”

In view of providing the information about the Latest technologies incorporated in the present manufacturing industries and what are the fields/sectors that the present students to look after to shape their career. In this connection, organized a national webinar on “Latest Technologies in Manufacturing” and “Area of focus for today’s Engineering students” on 14<sup>th</sup> October 2020.

The feedback forms also spread across the students/ participants by setting relevant parameters to observe its fulfillment.

The parameters were evaluated from grade 1 to 5 with one being the poor and five being the excellent. Fifty-seven responses received and these responses indicates the fulfillment of the objective of conducting this program. The feedback reflects that the majority of the participants expressed the appreciation further, this supports to meet few graduates’ attributes are PO1, PO5 and PO12.



Department of Mechanical Engineering,  
ATME College of Engineering, Mysuru



H.O.D.

Department of Mechanical Engineering  
ATME College of Engineering, Mysuru



Dr. Srinivasa K  
Professor and Head

Date:26.09.2020

**Report  
on  
International Webinar on Tolerance Stack-up Analysis**

International webinar conducted on **25<sup>th</sup>September 2020** through online on the topic **“Tolerance Stack-up Analysis”**. This webinar was organized with the intension to expose the **final year students (2020-2021)** on importance of tolerance providing to various mechanical components and its effect on manufacturing cost and the range of tolerance recommended to optimize/ control the cost of production of various components etc.

The invited speaker **Mr. Vinayak Naik** addressed our final year students with the above said topic and expressed best wishes to Final year students at the end of the session.

Mr. Devaraj M R welcomed the speaker, Prof. and Deans, Faculty and all the participants to the webinar. Mr. Yashwanth N rendered the vote of thanks to Speaker and all participants.

This event was coordinated by:

Mr. Devaraj M R,

Dr. Mohanakumara K C

Mr. Yashwanth N and

Mr. Niranjana kumar V S.

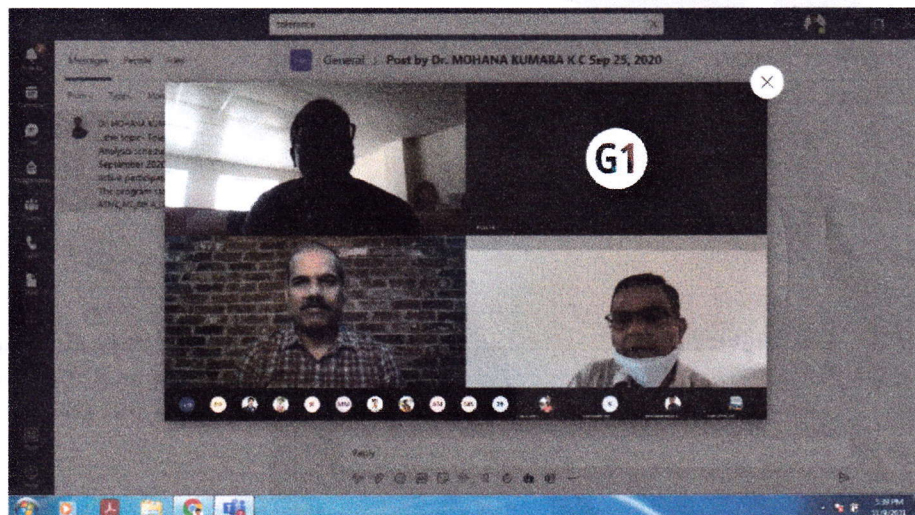

Tolerance Stack-up Analysis



**DEPARTMENT OF MECHANICAL ENGINEERING**

**Dr. Srinivasa K**  
**Professor and Head**

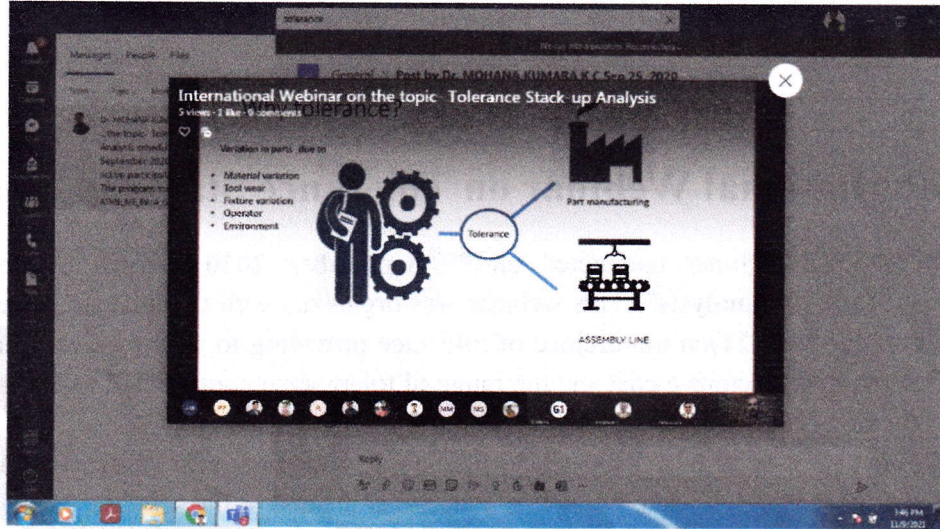

Demonstration is in progress with relevant examples

**Speaker:**

**Mr. Vinayak Naik**

Designation: Sr. Engineer

Email: metalsanaik@gmail.com

**Address: Midea America Research Center**

**2700 Chestnut Station Ct.**

**Louisville, KY 40229, USA**

**International Webinar**

**Topic: Tolerance Stack-up Analysis**

Date: 25<sup>th</sup> September 2020

Time: 3.00 PM

**Department of Mechanical Engineering**  
**ATME College of Engineering, Mysuru-28**

**HOD**  
**Department of Mechanical Engineering**  
**ATME College of Engineering**  
**Mysuru - 570028**



# A T M E

College of Engineering

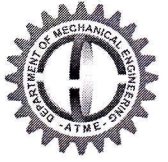

## Department of Mechanical Engineering

To,  
The Principal  
ATMECE,  
Mysuru

Date: 16.09.2020

Through, **Head of the Department**, Department of Mechanical Engg.

Department of Mechanical engineering is planning to conduct international webinar on **"Tolerance Stack-up Analysis"** on 25<sup>th</sup> September 2020 for final year students with the intension to give an insight on dimensional tolerances providing to various components and its effect on final assemblies.

Hence requesting you to kindly give permission to conduct this webinar on the above said date.

Thanking you sir.

Yours faithfully

Forwarded to Principal for kind approval.

*Ks A*  
H.O.D. 19/9/2020

Department of Mechanical Engineering  
ATME College of Engineering, Mysuru

*(DEVARAJ MR)*

Department of Mechanical Engineering  
ATME College of Engineering, Mysuru

Approved

*16/9*

ATME COLLEGE OF ENGINEERING

13th Kilometer, Mysore-Kanakapura-Bangalore Road, Mysore - 570 028 P: 0821-2593335 F: 0821-2593328  
Email : info@atme.in Web : www.atme.in

Department of  
Mechanical Engineering  
Accredited by NBA 2019-20 to 2021-22



**A T M E**  
College of Engineering



**International Webinar on- Tolerance Stack-up Analysis**

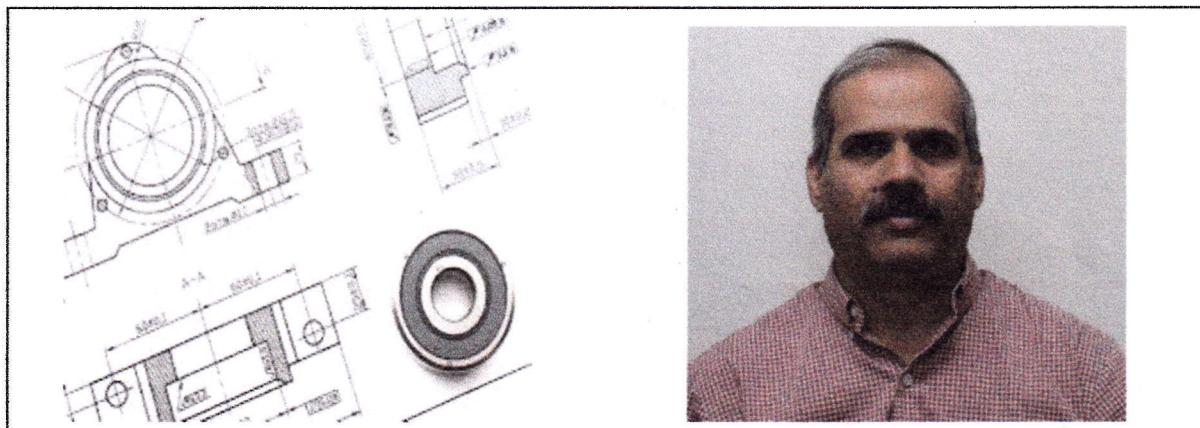

**Date on: 25<sup>th</sup>  
September  
Time :3.00 pm**

**Resource Person : Vinayak Naik**  
Sr. Engineer  
Midea America Research Center  
Louisville, KY 40229, USA

**Co-ordinators**

**Prof. Devaraj M R,**  
Asso. Prof., Dept. Mechanical Engineering  
**Dr.Mohanakumara K C,**  
Asst. Prof., Dept. Mechanical Engineering  
**Prof.Niranjana Kumar V S,**  
Asst. Prof., Dept. Mechanical Engineering  
**Prof.Yashwanth N,**  
Asst. Prof., Dept. Mechanical Engineering

**Convener**

**Dr. Srinivasa K**  
Prof. & Head  
Dept. Mechanical Engg.  
ATME College of Engineering

Registration Link: <https://forms.gle/d5mLJMW15ZSe1t318>

E-Certificates will be issued to those participants who will attend the entire session and fill the feedback form

**For information please Contact:**  
**Prof. Devaraj M R: 9972322811**  
**Prof: Yashwanth N: 9663994514**



# Feedback on International Webinar on- Tolerance Stack-up Analysis

31 responses

Publish analytics

## Name

31 responses

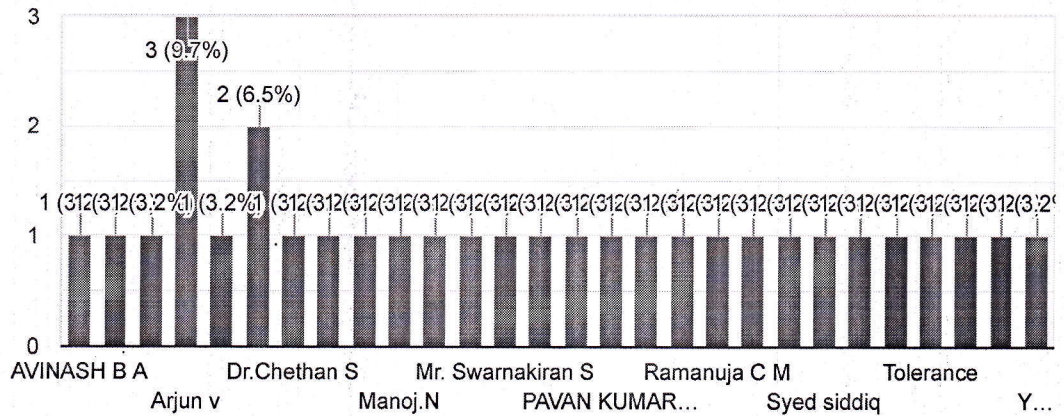

## Institute/Organization

31 responses

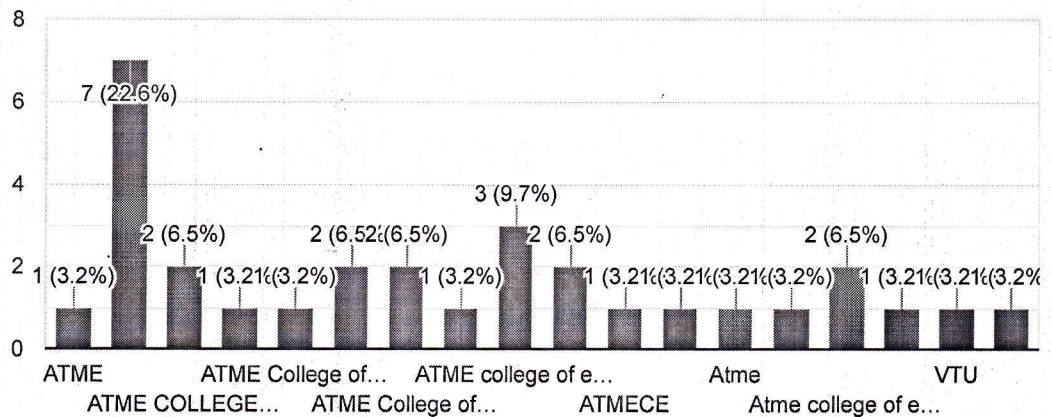

### Department

31 responses

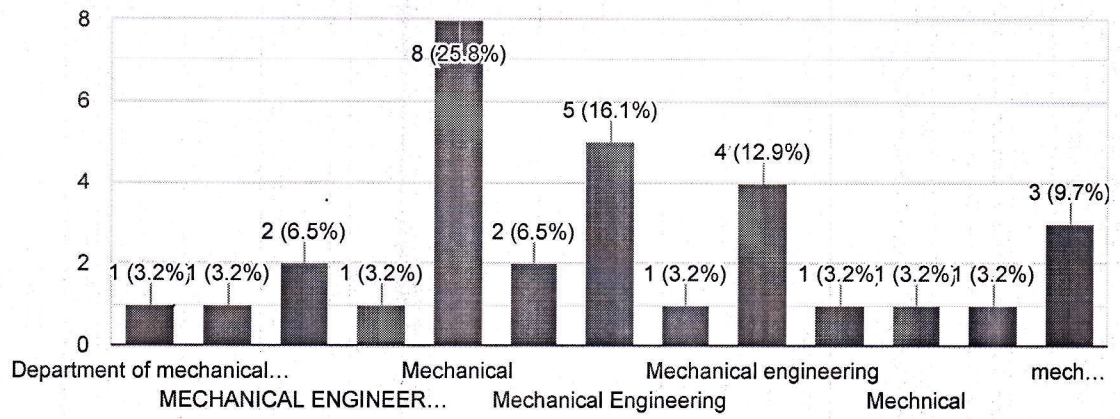

### Mobile No.

31 responses

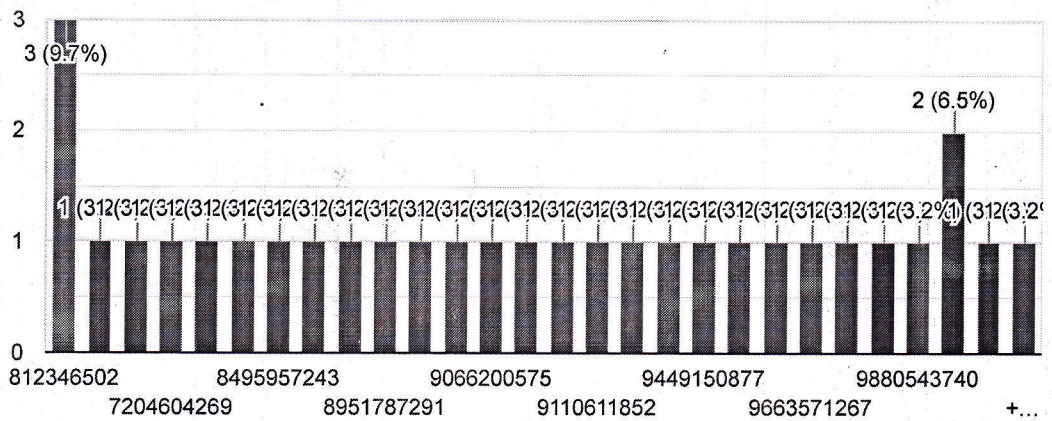

### Email

31 responses

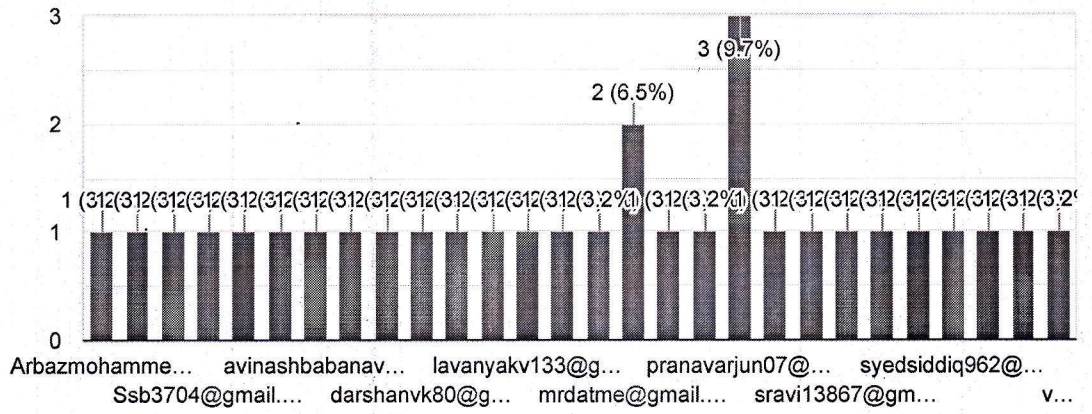

### The Content of the webinar met the expectations of the participants

31 responses

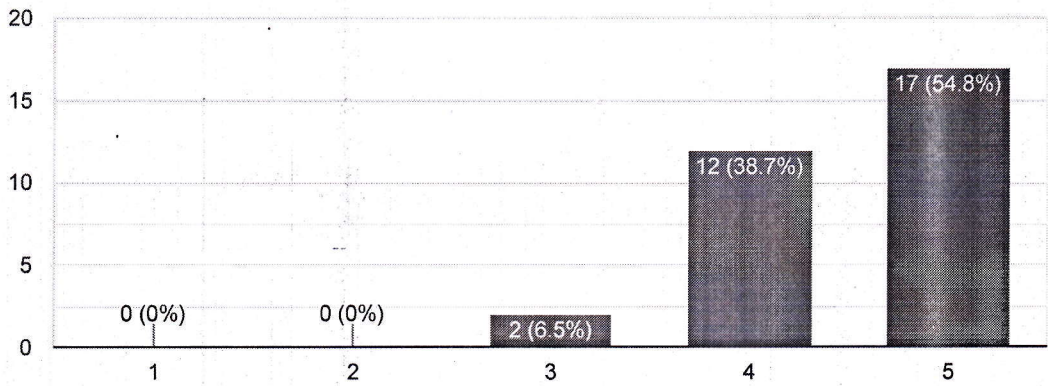

The Speaker provided adequate information and helped the participants to understand about the topic delivered

31 responses

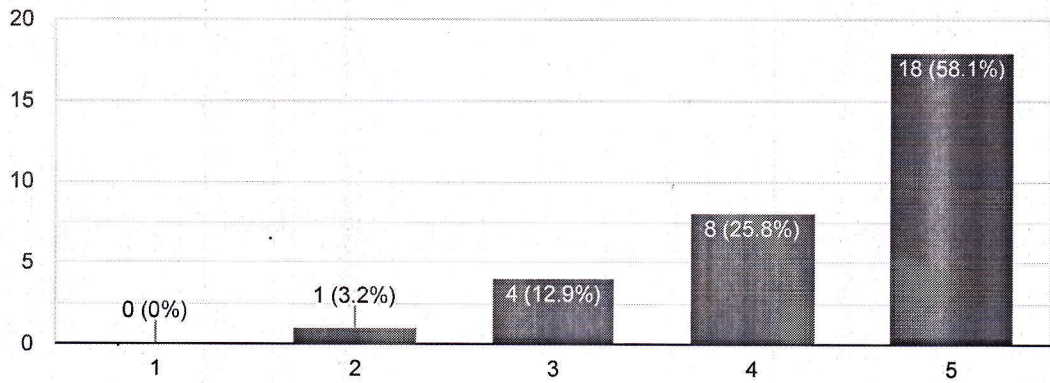

The Program is well Structured and objective of the webinar met effectively

31 responses

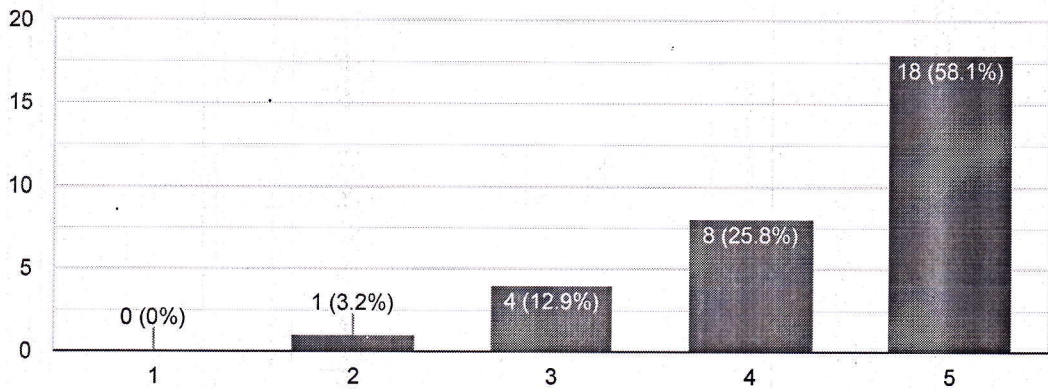

### Any other Commnets or Suggestions

12 responses

Overall good

Nil

Nothing

The session was very informative and expecting similar quality webinars in future

NILL

It was very informative session

Very useful information delivered thank you!

Fine

Verry valuable webinar met

This content is neither created nor endorsed by Google. [Report Abuse](#) - [Terms of Service](#) - [Privacy Policy](#)

## Google Forms

  
Department of Mechanical Engineering,  
ATME College of Engineering, Mysuru.

  
H.O.D.  
Department of Mechanical Engineering  
ATME College of Engineering, Mysuru





**Department of Mechanical Engineering**

**INFERENCE**

**International Webinar on  
“Tolerance Stack-up Analysis”**

In view of providing the insight on dimensional tolerances providing on various engineering components and its effects on final assemblies, this webinar was conducted on **25<sup>th</sup> September 2020** to final year students.

The feedback forms spread across the students/ participants by setting relevant parameters to observe its fulfillment.

The parameters were evaluated from grade 1 to 5 with one being the poor and five being the excellent. Thirty-one responses were received and these responses indicates the fulfillment of the objective of conducting this program. The feedback reflects that the majority of the participants expressed the appreciation. further, this supports to meet few graduate attributes are PO1 and PO12.

Department of Mechanical Engineering,  
ATME College of Engineering, Mysuru

**H.O.D.**  
Department of Mechanical Engineering  
ATME College of Engineering, Mysuru



A T M E

College of Engineering



NBA  
ACCREDITED

Affiliated to VTU, Belagavi; Approved by AICTE, New Delhi and Recognised by Government of Karnataka  
Programs accredited by NBA, New Delhi - CV, EC, EE & ME (Validity: 2019-20 to 2021-22)

Report  
on  
National Level Online FDP on  
**“New Avenues and Role of Faculty in  
Effective Implementation of NEP-2020 In HEI’s”**  
Organized by  
ATME College of Engineering

ATME College of Engineering had organized a National Level Faculty Development Program on “New Avenues and Role of Faculty in Effective Implementation of NEP-2020 in HEI’s” on 29<sup>th</sup> January 2021 through Online Platform.

The event was organized to understand the basic elements of NEP-2020, to discuss the Features of NEP 2020 and to understand the role of faculty in the implementation NEP 2020.

**Dr. Karisiddappa**, Honorable Vice Chancellor, VTU, Belagavi presented the keynote address. **Prof. T. V. Kattimani**, NEP Draft Committee Member, Vice Chancellor, Central Tribal University, Andhra Pradesh and **Dr. Govinde Gowda M S**, Dean-Academics, ATME College of Engineering, Mysuru were the speakers for the Faculty Development Program.

**Dr. L Basavaraj**, Principal, ATMECE, Mysuru rendered the welcome address and gave quick insights on NEP-2020.

**Sri. L Arun Kumar**, Honorable Chairman, ATMECE, Mysuru in his presidential address said that COVID-19 pandemic has affected many sectors and the NEP-2020 has brought a welcoming change in the education sector. He further said the policy has highlighted the importance of education in nation building and highlighted the changes addressed in the policy. He envisaged how the policy aims to meet the needs of 21<sup>st</sup> Century and it provides a silver lining amidst the uncertain pandemic situation.

**Dr. Karisiddappa**, Honorable Vice Chancellor, VTU Belagavi in his keynote address said, National Educational Policy-2020 is a transformational concept and the role of students in Higher Technical Education is pivotal. It aims at providing the right direction, perspective and techniques that will help teachers adopt to the new curricula structure, to rebuild their teaching methods and explore new realms of research. He spoke on the drawbacks and challenges in existing education system and employability. He said the policy will open a student centric window and give them an opportunity to explore the field of their choice in HEI. He spoke on the compliances in education through measurable outcomes, Multiple entry and exit scheme. He stressed, we need to have a curriculum structure, where

ATME COLLEGE OF ENGINEERING

13th Kilometer, Mysore-Kanakapura-Bangalore Road, Mysore - 570 028 P: 0821-2593335 F: 0821-2593328

Email : info@atme.in Web : www.atme.in



Affiliated to VTU, Belagavi; Approved by AICTE, New Delhi and Recognised by Government of Karnataka  
Programs accredited by NBA, New Delhi - CV, EC, EE & ME (Validity: 2019-20 to 2021-22)

the students get employable in industries. He said colleges should aim at Quality assessment through Accreditation from NBA/NAAC and focus towards degree awarding institution. He highlighted opportunities for Faculty members in Teaching, Research in higher education through National Education Policy and said Karnataka has the potential to become good destination for Higher Education.

**Session-I** was delivered by **Dr. Govinde Gowda M S**, Dean-Academics, ATME College of Engineering, Mysuru on 29<sup>th</sup> January 2021. He started the session and addressed the importance of the NEP. He briefed about the schooling education and in detail explained about Multiple entry and exit scheme. He further gave insights about central eligibility test, Pre service Teacher education, Teacher recruitment and employment, Teacher audit/Performance appraisal and Innovative Teaching methods. He gave various good practices as an example that are followed in ATMECE during his session.

**Session-II** was delivered by **Prof. T. V. Kattimani**, NEP Draft Committee Member, Vice Chancellor, Central Tribal University, Andhra Pradesh on 3<sup>rd</sup> February 2021. He started the session and spoke on the benefits and challenges in current education system. He spoke in detail on the translation of technological information to its regional language to minimize the language barrier in various state of India. He explained how the technology has evolved in the state of Jharkhand and where tribes gradually evolved utilization of rural technology. He further gave insights on Solid Waste Utilization, and the role of Engineers, Scientists, Students to come up with Innovative Indigenous Technology. Finally, he concluded that Teachers should become Life-long Learners to upgrade their skills & to utilize the skillset during Career Counselling of students.

About 105 participants from various Engineering colleges across the India participated in the event. Questionnaire and discussion was held after each session.

As a part of the program, Mock & Pre-assessment test was conducted on 27<sup>th</sup> and 28<sup>th</sup> January respectively to assess the awareness about the NEP. Post-assessment test was conducted on 4<sup>th</sup> January after the conclusion of the program to evaluate how effectively the contents reached the participants. Mr. Thejkumar J, Assistant Professor, Department of Mechanical Engineering rendered the Vote of Thanks. The event was streamed live through YouTube.

The online Faculty Development Program was coordinated by Dr. Yathisha L, Associate Professor, Dept. of ECE, Mrs. Sunitha Patel M S, Assistant Professor, Dept. of CSE, Mr. Thejkumar J, Assistant Professor, Dept. of ME, Mrs. Sneha N P, Assistant Professor, Dept. of CSE, Mr. Shreeshayana R, Assistant Professor, Dept. of EEE, Mr. Girish M, Assistant Professor, Dept. of



**Session-I:**

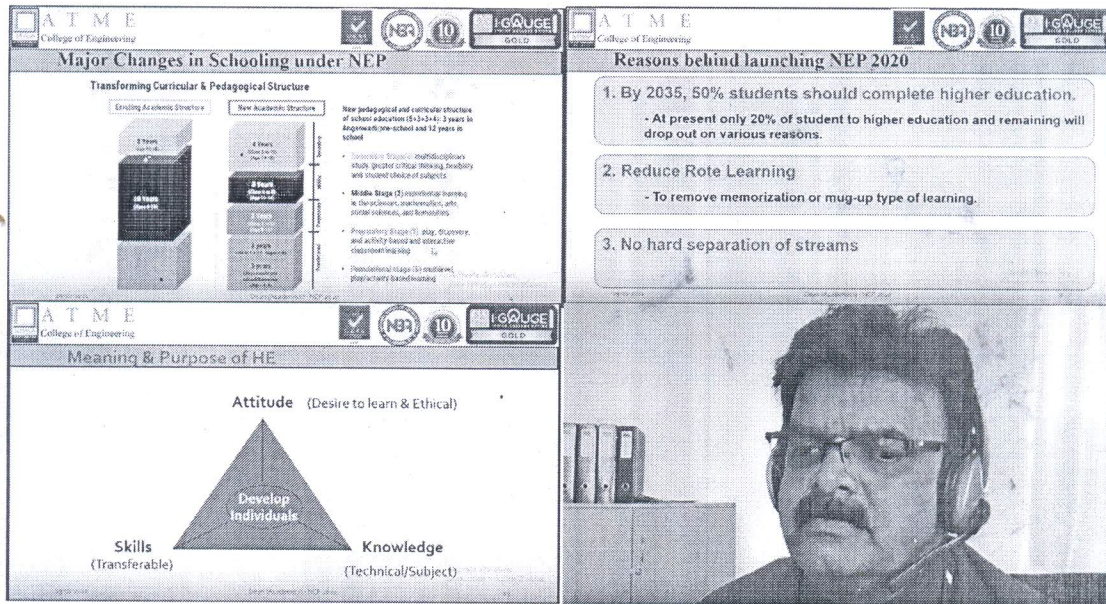

Fig 4: Dr.M S Govindgowda, Dean-Academics, ATMECE delivering the session

**Session-II:**

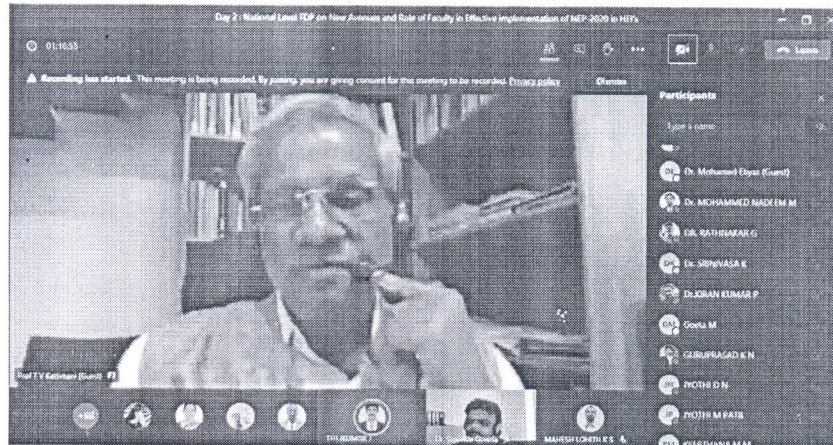

Fig 5: Prof. T. V. Kattimani, NEP Draft Committee Member, Vice Chancellor, Central Tribal University, Andhra Pradesh delivering the session



ECE, Mrs. Bharathi B, Assistant Professor, Dept. of CE Mr. Srivathsa H U Assistant Professor, Dept. of CE, ATME College of Engineering.

### Event Photos

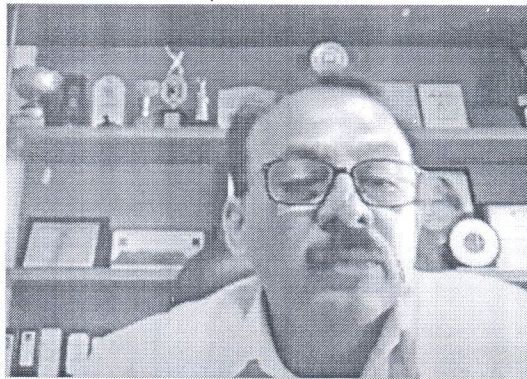

Fig1: **Dr. L Basavaraj**, Principal, ATMECE, rendering the Welcome Address



Fig 2: **Sri. L Arun Kumar**, Honorable Chairman, ATMECE, rendering Presidential Address



Fig 3: **Dr. Karisiddappa**, Honorable Vice Chancellor, VTU Belagavi rendering Key note address



# A T M E

## College of Engineering



# NBA ACCREDITED

Affiliated to VTU, Belagavi; Approved by AICTE, New Delhi and Recognised by Government of Karnataka  
Programs accredited by NBA, New Delhi - CV, EC, EE & ME (Validity: 2019-20 to 2021-22)

### Session in MS Teams

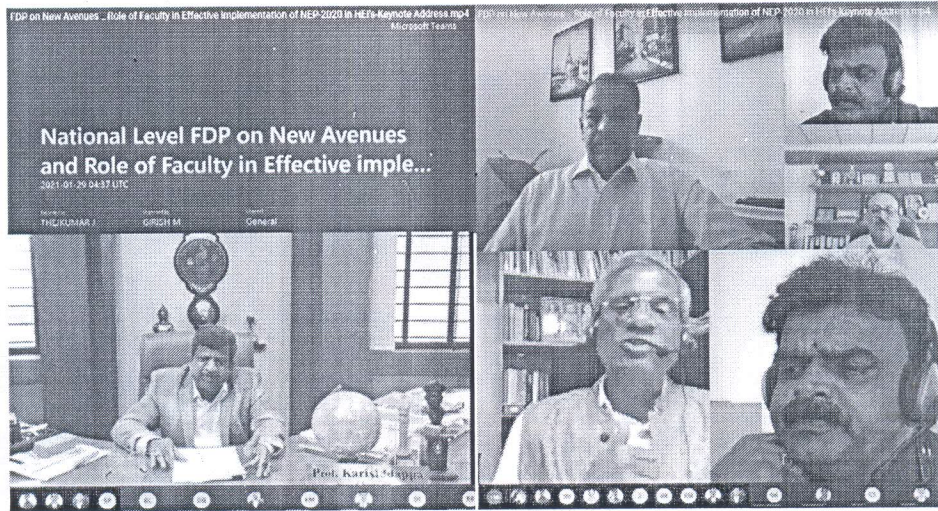

### Feedback Report

Question: The content of the FDP is relevant to HEI at the present scenario

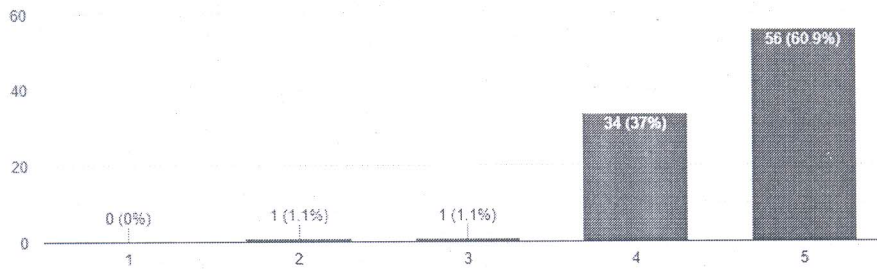

Question: The Objective of the FDP is clearly set

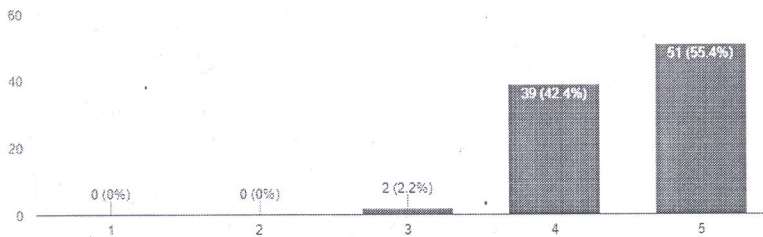

ATME COLLEGE OF ENGINEERING

13th Kilometer, Mysore-Kanakapura-Bangalore Road, Mysore - 570 028 P: 0821-2593335 F: 0821-2593328

Email : info@atme.in Web : www.atme.in



**Question: The Speaker provided adequate information and well organized in the session**

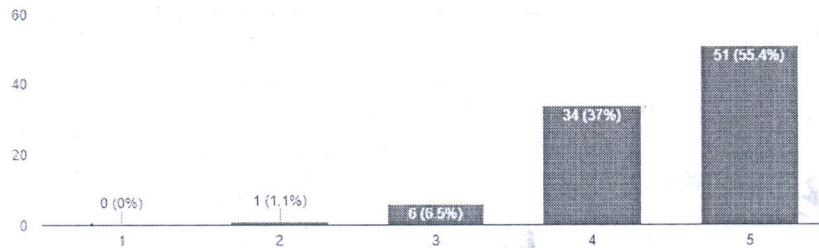

**Question: The Speaker provided adequate time for questions and answered them satisfactorily**

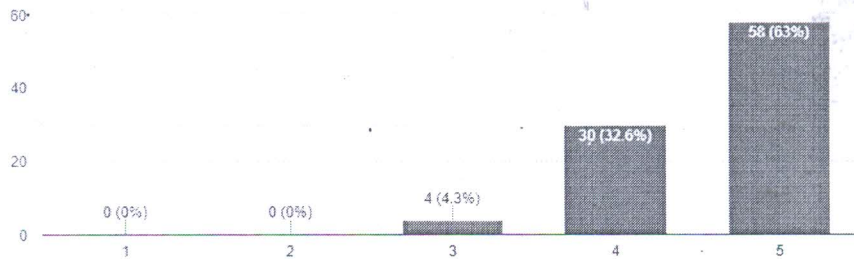

**Question: The sessions were well organized and executed**

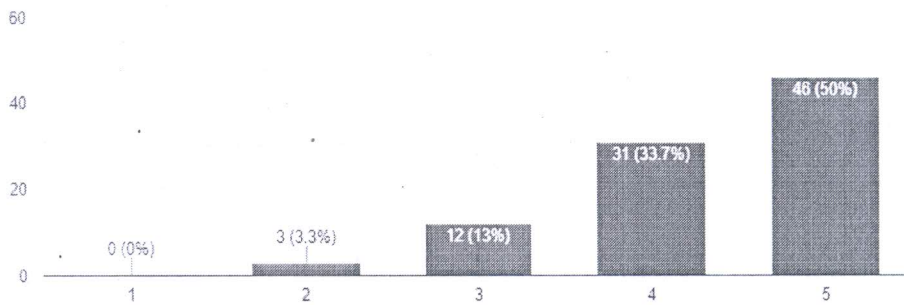

*MS*  
(M S Sunitha Patel)

*Arunde*  
MOD  
Dept. of Computer Science & Engg  
ATME College of Engineering  
Mysuru-570020



## Webinar on IPR & its Role in Research & Innovation

Date: 20/11/2020 Time: 10.00 AM to 11.30 AM

### Objectives:

The webinar aims at providing fundamental background on Intellectual properties which include Patents, Copyrights, Designs, and Trademark etc. The participants would understand how to make use of the technology transfer offices (IPR Cell) to protect and commercialise IP generated through research.

### Resource Person:



Dr Prachi Chopra

#### Experience:

- President, Delhi Innovation Council: WICCI - Women's Indian Chamber of Commerce and Industry.
- Founder & Director: Intellect Bastion is an Intellectual Property services and solutions provider firm that assists Inventors, startups, MSME and law firms in their IPR.
- Professor Bada Business Pvt. Ltd.

#### Education:

- Ph.D in Digital signal and image processing in Indira Gandhi Delhi Technological University for Women, Kashmiri Gate, Delhi.
- Harvard University- Online Course on Entrepreneurship in emerging Economics.- Business.

### Program Convenors:

**Dr Bhagyashree S R**

Dean Research  
Professor, Department of ECE  
ATMECE, Mysuru

**Dr. Parthasarathy L**

IEEE Student Branch Counselor  
Professor & Head, Department of EEE  
ATMECE, Mysuru

### Program Coordinators:

**Dr. Mohammed Nadeem M**  
Assistant Professor,  
Department of ME

**Mrs. Nasreen Fathima**  
Assistant Professor  
Department of CSE

**Mr. Vinod Kumar P**  
Assistant Professor  
Department of EEE

## Platform: Microsoft Teams

<https://forms.gle/4qmRv73YPdKHtJCKA>



## **IPR AND ITS ROLE IN RESEARCH AND INNOVATION**

ATME College of engineering had organised a webinar on “*IPR and its role in research and innovation*” on Nov 20<sup>th</sup> 2020. The webinar was conducted in MS Teams platform and a total of 115 participants from ATMECE and other institutions had participated. The webinar was scheduled at 10AM with formal introduction about the webinar followed by brief introduction of resource person.

Dr. Prachi Chopra, President, Delhi innovation council was kind enough to accept our invitation as resource person to educate the faculty members of various educational streams about the importance of IPR and its role in research and innovation.

Dr. Bhagyashree S R, Dean-Research and professor, ATMECE and Dr. Parthasarathy L, IEEE student branch counsellor, Professor and Head, Dept. of EEE ATMECE, were the convenors of the program.

Dr. Md Nadeem M, Asst. professor, Dept of ME, Mrs. Nasreen Fathima, Asst. professor, Dept of CSE and Mr. Vinod Kumar P, Asst. professor, Dept of EEE Organised and hosted the webinar.

Dr. Prachi chopra discussed about the importance of intellectual property rights and the crucial role of intangibles such as technology, design and branding in international manufacturing. Analysis was done by case studies pertaining to various innovations.

Dr. Prachi chopra emphasized the importance on protecting the IP law by, for example, patents, copyright and trademarks with the help of IP law. She motivated the audience to earn recognition or financial benefit from what they invent or create. By striking the right balance between the interests of innovators and the wider public interest, the IP system could be aimed to foster an environment in which creativity and innovation can flourish.

As is the case with inventions, utility models’ patents and patents are relevant for protecting, managing, exploiting innovations. Patents are the preferred IP right sought for the protection of technological innovations. Dr. Prachi mentioned that the number of patents owned by an enterprise is often used as one of the main indicators for determining its innovation intensity and patents are used as a measure of output of innovation. While such an approach is useful, it



**A T M E**  
College of Engineering

does not look at the role of the IP system as a whole in facilitating the successful introduction of innovative products in the marketplace.

Dr. Prachi Chopra answered the questionnaires raised by the participants and gave them suggestions providing information related to patents, copyrights and trademark etc.

At the end Dr. Bhagyashree S R concluded the webinar by giving vote of thanks to Dr. Prachi chopra, Management of ATMECE, Dean, HODs and all the participants. Feedback form was floated to all the participants through participants respective email IDs for effective management and documentation.

**Dr. Parthasarathy I**  
**IEEE Student Branch Counsellor**